

EVALUATING DESIGN OF MORTISE AND TENON FURNITURE JOINTS UNDER BENDING LOADS BY LOWER TOLERANCE LIMITS¹

*Mesut Uysal**

Assistant Professor
Department of Forest Products Engineering
Furniture and Wood Application and Research Center
Bursa Technical University
Bursa 16310, Turkey
E-mail: mesut.uysal@btu.edu.tr

Eva Haviarova†

Professor
Department of Natural Resources and Forestry
Purdue University
West Lafayette, IN 47907
E-mail: ehaviar@purdue.edu

(Received January 2021)

Abstract. This study aimed to estimate the design value for mortise and tenon joints. In this respect, the design value for static load tests was determined using lower tolerance limit methods. A lower tolerance limit value at 0.99/0.99 confidence/proportional level was chosen as a design value (199.05 N.m) to secure higher joint reliability in a furniture frame. A side frame of a simple wooden chair was theoretically analyzed to obtain internal forces acting on joints, whereas the load of 1000 N was applied in the vertical direction on the top of the front leg. A full-frame chair with mortise and tenon joints was then designed using the calculated lower tolerance limit design value. This action ensured that joints would not be overstressed when a chair is under static load while not exceeding 2000 N. By applying this method, all chairs should survive static load up to 2000 N. While performing cyclic front-to-back load test, all tested chairs met the American Library Association requirements for light-duty service load, specified for household chairs. This study demonstrates that a joint failure could be prevented under expected loads specified by the standard if the joint design value is known.

Keywords: Furniture strength design, tolerance analysis, design value, mortise and tenon joints.

INTRODUCTION

The product design process consists of three steps: 1) target settings, 2) product design, and 3) development and product quality validation stage. A successful product design and development process are required to construct reliable products (Lee et al 2015). Therefore, this study aimed to investigate the reliability of chair frames constructed with mortise and tenon joints, in which design values are determined using lower tolerance methods.

A chair frame may be subjected to dozens and hundreds of unpredictable loads (Fig 1). At the beginning of service life, a piece of furniture has ultimate strength capacity. This structure is then exposed to normal or abusive loads, and its strength would be expected to reduce because of fatigue (Nelson 1979). Joints are the weakest part of furniture structure, so very typical failures may occur due to loose or failed joints rather than fractures in legs or other members (Eckelman et al 2003). When furniture joints are overstressed and exceed the first-crossing point as shown in Fig 2, the structure will fail (Erdil et al 2004). Therefore, furniture joints must be designed to resist all loads imposed in service.

* Corresponding author

† SWST member.

¹ The copyright of this article is retained by the authors.

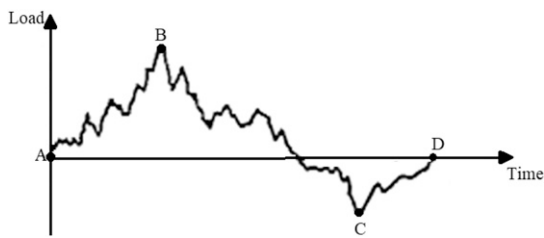

Figure 1. Unpredictable load history (Nelson 1979).

Mortise and tenon (MT) joints (Fig 3) have been used in furniture frame construction for centuries. They are favored despite using the glued or knockdown joinery techniques because of their higher strength and stiffness in construction. The structural behavior of MT strength can be divided into three groups:

1. Tight-fitting rectangular MT (Fig 4[a]): behaves like a mechanical joint, so its strength can be calculated as strength of the tenon itself (Eckelman 2003).
2. Tight-fitting MT but top and bottom of the mortise are rounded (Fig 4[b]): resists to torsional shear strength on the glue line between walls and mortise and sides of tenon under bending force. Hence, its strength relies on tenon length and width but not on thickness until it fails due to bending (Eckelman 2003).
3. Poor matched MT joint (Fig 4[c]): its strength depends on the glue line, and joints fail due to withdrawal of tenon or insufficient support on top and bottom of the mortise. In using short tenon in joint, MT joints behave as dowel joint until glue line failure. Then, its longitudinal axis is slightly stressed (Eckelman 2003). This

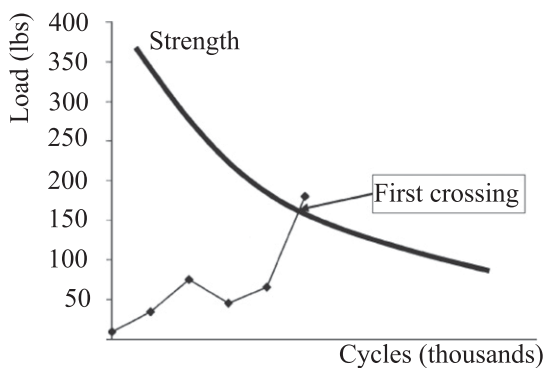

Figure 2. First-crossing point concept (Erdil et al 2004).

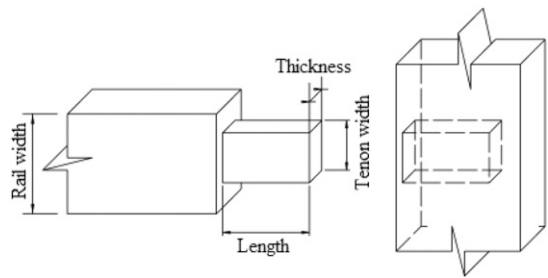

Figure 3. Mortise and tenon joint configuration (Eckelman 2003).

MT joint type (called blind MT) is mainly used in frame constructions. In the design of MT joints, tenon length and width and shoulder effect come into prominence. When both tenon width and length are increased, the joint becomes stiffer. Besides, joint width has a more significant effect on joint flexibility than tenon length. Larger shoulders on the MT joints' rail members contribute higher stiffness and strength to the joint (Hill and Eckelman 1973).

Numerous studies were conducted to estimate the strength of MT joints. The predictive expression for bending strength of mortise and tenon joints by considering shear strength of wood species, adhesive types, rail width, tenon depth, tenon length, and tenon fit which is the difference between tenon and mortise thickness was studied (Hill and Eckelman 1973). The bending strength of rectangular MT joints by considering wood species, adhesive types, rail width, tenon depth, and tenon length was estimated (Erdil et al 2005). Shoulder effects on bending moment capacity of round mortise and tenon joints were estimated (Eckelman et al 2006). Bending strength of MT joints by considering the effects of adhesive types and tenon sizes was studied (Kasal et al 2013). Bending moment capacities of MT joints under compression and tension loadings by considering wood species, tenon sizes, and adhesive types were estimated (Kasal et al 2015). However, these studies followed deterministic approaches based on prediction analysis, which estimates a single value for future data. In this study, tolerance analysis is used to estimate a proportion level of future data with a confidence level of

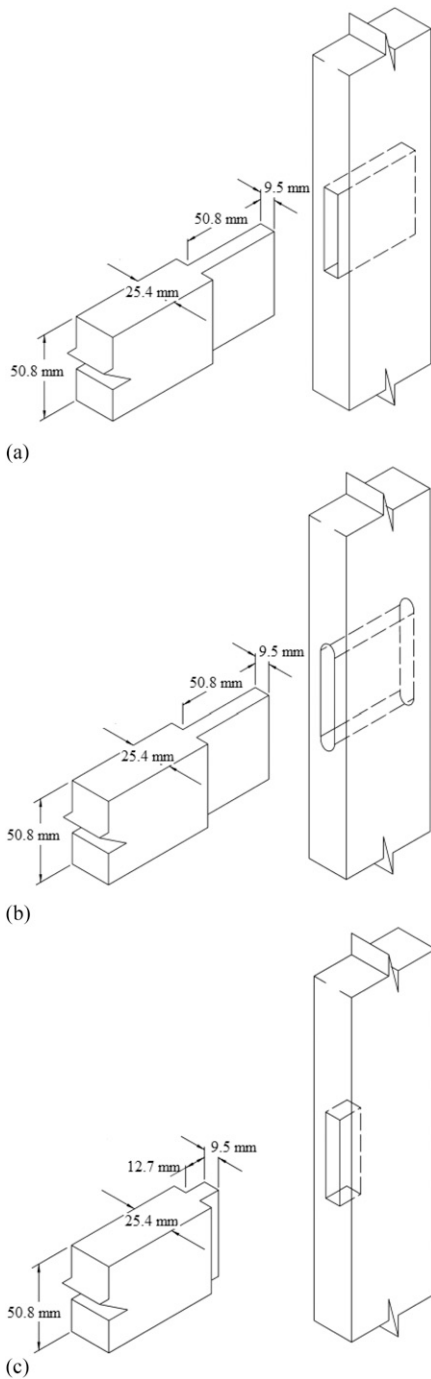

Figure 4. (a) Tight mortise and tenon, (b) tight tenon, and (c) poor match mortise and tenon (Eckelman 2003).

sample data. Although a design value is obtained with these methods, it is ensured that the load level is known and will not overstress material in service until its strength would reach the first-crossing point, as shown in Fig 5 (URL-1).

Wood has been used in conventional structures, so its allowable design values were defined for the intended utilization. It is vital to mention that wood materials used in furniture construction have different mechanical behaviors from wood materials used in timber engineering because furniture members and joints are of small sizes and usually use defect-free wood (Eckelman 1974). Therefore, a design value should be established for wood material in furniture engineering, too. In the engineering design of furniture, knowing material strength is vital to design reliable and durable construction. However, wood is orthotropic material and works differently in all three fiber directions: longitudinal, tangential, and radial, as shown in Fig 6 (FPL 2010). Besides, some manufacturing errors could also affect the structural reliability of furniture during production. When large-scale production begins, the level of variation and occurrence of the product failure usually increase (Wencheng 2011). Thus, the lower tolerance limit (LTL) method, which is one of the probabilistic approaches, is a beneficial procedure to acquire uncertainties of different parameters (Fink and Kohler 2015). The studies have been conducted to determine LTL values for L-shaped MT joints

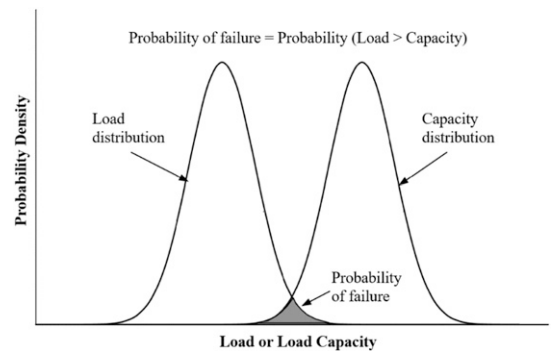

Figure 5. Comparison of load and capacity distribution (URL-2).

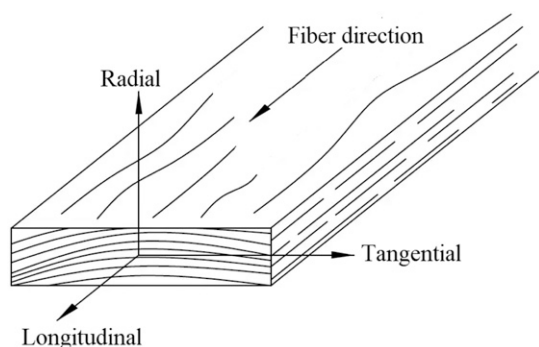

Figure 6. Wood fiber direction (Wood Handbook 2010).

(Eckelman et al 2017a) and T-shaped MT joints (Eckelman et al 2017b). Besides, LTLs for rectangular MT joints (Eckelman et al 2016) and screw (Uysal and Haviarova 2019) were determined. Also, dowel joints on the chair frame were designed based on the estimated design value by using the LTL method (Uysal and Haviarova 2018)

In this study, the intent is to enhance the structural reliability of the furniture frames by increasing reliability of the joints. Thereby, market success for furniture producers can be improved because product reliability is a concern and influences product sustainability, human safety, and the global competitive market (Domljan et al 2004).

This study aimed to estimate the design values of MT joints with the LTL method. In doing so, 1) the LTLs for bending strength of T-shaped mortise and tenon joints are determined, 2) MT joint is designed based on given LTL values at desired confidence/proportion (C/P) level, and 3) strength of a full-frame chair with MT joints designed based on an LTL value is determined under static and cyclic front-to-back load performance test.

MATERIALS AND METHODS

Wood Materials

In this study, northern red oak (*Quercus rubra* L.) was used as wood material because of its wide utilization in the furniture industry. Red oak lumber was used to construct specimens of both

T-shaped MT joints and full-chair frames. Kiln-dried lumbers were obtained from a local sawmill located in northeast IN.

Adhesives

Forty percentage solid content polyvinyl acetate (PVA) adhesive was used to construct both joint and chair specimens. This adhesive type is a thermoplastic, water-based emulsion and well suited for gluing porous materials, eg wood (Khan et al 2013). Although it would fail under sustained stress and creeps at lower loads because of being thermoplastics, the advantage is that PVAc bonds permit slight movement without any failure in a joint assembly. Where grain orientation is perpendicular to the glue line, its deformability is advantageous for the ductility of joints (Marra 1992).

Construction of T-Shaped Mortise and Tenon Joints

All lumbers were first conditioned to and then maintained at 7% MC for 1 mo. Afterward, boards were subsequently machined to a thickness of 22.23 mm, and then cut to visually defect-free 63.50 mm wide by 336,55 mm long blanks. Rails and posts for joint specimens were randomly selected from the pool of the blanks.

Tenons of 31.75 mm long by 38.10 mm wide by 9.50 mm thick were cut with the tenoning machine, as shown in Fig 7. Matching mortises were cut on a multichisel router with a tolerance of

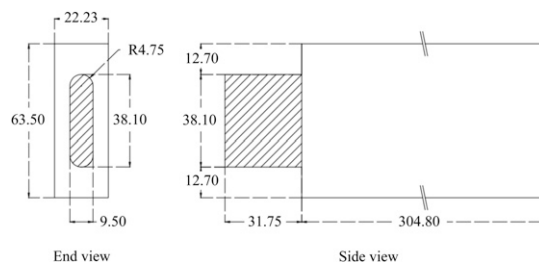

Figure 7. Configuration of rail with tenon for T-shaped MT joints (mm).

0.127 mm. The faces of the tenons and the mortise walls were coated with PVAc adhesive, and the full length of the tenons was inserted into the mortises and clamped in place. Specimens remained clamped for 24 h. They were then kept in the conditioning room for at least 1 wk at 7% MC before testing (Erdil et al 2005).

T-Shaped Joint Test under Bending Force

All tests were conducted on an MTS testing machine with a load capacity of 4450 N. Test setup is shown in Fig 8. The edgewise load was applied on the rail with a 254-mm-long moment arm at a rate of 12.7 mm/min. Tests were continued until nonrecoverable failure occurred on joints (Erdil et al 2005).

$$M = F \times L, \tag{1}$$

where M is the bending moment capacity of joints (N.m), F is the ultimate failure load of joints (N), and L is the moment arm (m).

Sample Size Determination for Tolerance Limits

Sample sizes in a study are critical to satisfy assumptions in statistical analysis—eg normality assumption. To satisfy the normality assumption in tolerance intervals, minimum sample sizes must be determined to check whether it is enough to explain the hypothesis test or not. The sample size determination for normal tolerance intervals using a modified Faulkenberry–Weeks method (Faulkenberry and Weeks 1968) by using a

historical dataset was studied (Young et al 2016). An R-tolerance package to calculate the minimum sample size requirements for normal datasets was provided (Young 2016). The adapted R-code from Young (2016) for one-sided LTL is given in the following text:

```
norm.ss(x = data, alpha = 1 - γ,
        P = P, side = 1, spec = c(̄X - 3s),
        method = "YGZO", hyper.par
        = list(mu.0 = ̄X, sig2.0 = s²)).
```

A preliminary study should be carried out by considering the requirements in the following text to set minimum sample size requirement for tolerance limits (Young et al 2016):

1. Design of historical data and current data must come from the same sources.
2. To not damage the homogeneity assumption in the dataset, the manufacturing and testing process must be similar.
3. Generated historical data must be stable.

In respect of these requirements, 30 specimens were constructed according to the central limit theorem (Kwak and Kim 2017), which satisfies enough sample size to assume that data are normally distributed. Besides, the Shapiro–Wilks normality test should be applied not to damage the tolerance limits analysis with a significance level (α) of 0.05 and to check whether the dataset is normally distributed or not. In this case, the following hypothesis tests were sought:

- H_0 : Data are normally distributed
- H_a : Data are not normally distributed

Construction of specification limits is significant to determine minimum sample sizes. Historical data can characterize future samples (used in tolerance analysis) based on how closely they follow their specification limits. In this respect, LTLs should not exceed lower specification limits ($LSL > LTL$) to indicate that the analysis is under statistical control. It is somewhat related to

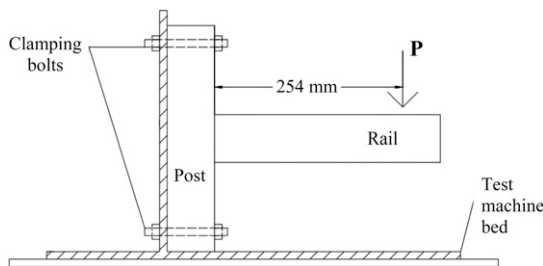

Figure 8. Test configuration of T-shaped joints.

using 3 standard deviations as a threshold when one determines if an observation is a possible outlier when analyzing residuals from regression fit (Young et al 2016). Therefore, the LSL was constructed by

$$LSL = \bar{X} - 3s, \tag{2}$$

where \bar{X} is the sample mean and s is the sample standard deviation.

Determination of LTLs for Rectangular Mortise and Tenon Joints

The equation for LTLs for the normally distributed dataset is given by Natrella (1963)

$$LTL = \bar{X} - (k_{(n,\gamma,P)} \times s), \tag{3}$$

where \bar{X} is the sample mean, $k_{(n,\gamma,P)}$ is the tolerance factor for specified sample size and C/P level, and s is the sample standard deviation. Besides, it is calculated by using R-code as given in the following text (Young 2016):

```
normtol.int(x = data_name,
            alpha = 1 - gamma, P = P, side = 1).
```

If datasets are not normally distributed, normalizing transformation methods are sought—eg logarithmic transformation (log-normal data) (URL-2). Then, if transformed data are normally distributed, logarithmic values for LTLs are calculated, and then, data points are converted to integer values. If transformation does not work, other continuous distributions, such as the Weibull distribution (Young 2016), are used. In this case, the Kolmogorov–Smirnov test is conducted to check whether the data fit or do not fit the Weibull distribution. The R-code is given in the following text to obtain LTLs if there is a good fit of data:

```
exttol.int(x = data_name,
            alpha = 1 - gamma, P = P,
            dist = "Weibull", NR.delta = 1e - 8).
```

The nonparametric tolerance analysis is used if data do not fit the Weibull distribution (URL-2).

The nonparametric analysis is a more conservative method than others. However, a designer must be careful while applying it because it may give the lowest values in the dataset at higher C/P levels. The binomial probability is used to obtain LTLs by using nonparametric methods (Lane 2019):

$$P(X_i < \xi) = \binom{n}{x} \times P^x \times q^{(n-x)}, \tag{4}$$

where X_i is the number of data below the LTL value; ξ is the LTL value; n is the number of observations; $P(X_i < \xi)$ is the significance level ($\alpha = 1 - \gamma$); x is unknown in the equation, which is the number of values below the LTL value; P is the proportion level; and q is equal to $(1 - P)$. Besides, R-code was provided to obtain LTLs for nonparametric tolerance analysis (Young 2016).

```
nptol.int(x = data_name,
          alpha = 1 - gamma, P = P,
          side = 1, method = "WILKS,"
          upper = NULL, lower = NULL).
```

Design of Mortise and Tenon Joints

In this study, MT joints are first considered as a mechanical joint; that is why, the bending stress of this joint can be calculated by using the equation in the following text (Hibbeler 2012):

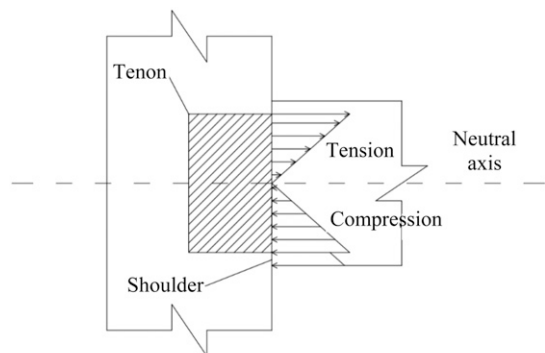

Figure 9. Tension and compressive stresses on MT joint (Erdil et al 2005).

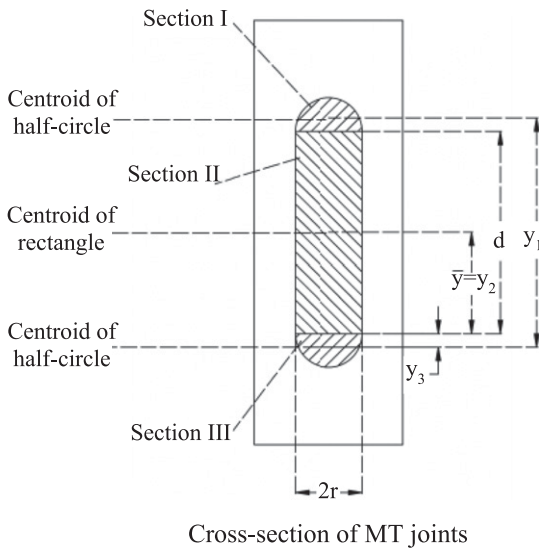

Figure 10. Cross section of MT joints.

$$\sigma = \frac{M \times c}{I}, \tag{5}$$

where σ is the normal stress due to bending, M is the bending moment, c is the distance between the neutral axis and bottom edge of the tenon, and I is the moment of inertia of the tenon. The bending stress of the tenon in vertical loading is illustrated in Fig 9.

When adequate tenon length is assured, the width of the tenon is the most effective parameter affecting joint strength. In this case, joint strength (assessed by bending moment capacity) can be calculated (Eckelman 2003):

$$M = 0.7 \times \tau_{\text{wood}} \times (0.57T_w + 0.24R_w) \times B \times C \times D, \tag{6}$$

where τ_{wood} is the shear parallel to the grain of the wood, T_w is the width of the tenon, R_w is the width

Table 1. Member sizes in chair construction.

Member	Thickness (mm)	Width (mm)	Length (mm)
Front leg	38.10	38.10	400.00
Rear leg	38.10	38.10	800.00
Rail	22.23	50.80	323.80
Side stretcher	22.23	22.23	323.80
Midstretcher	22.23	22.23	339.70

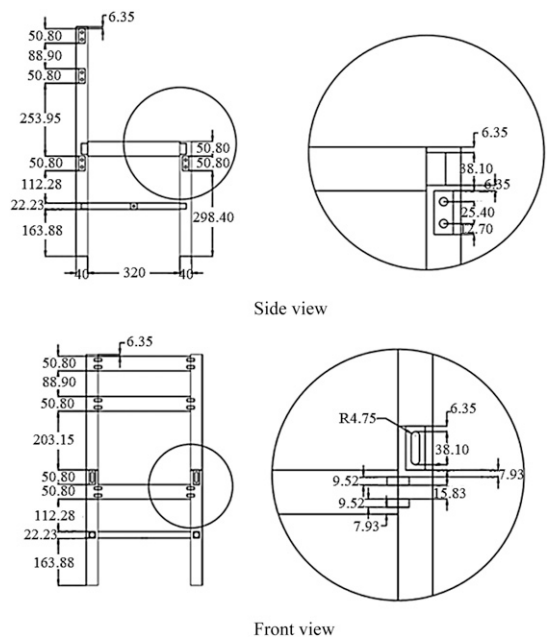

Figure 11. Chair configuration (mm).

of the rail, B is the length factor, C is the adhesive factor, and D is the tenon–mortise tolerance factor. These factors are obtained from the study conducted by Eckelman (2003) in USS

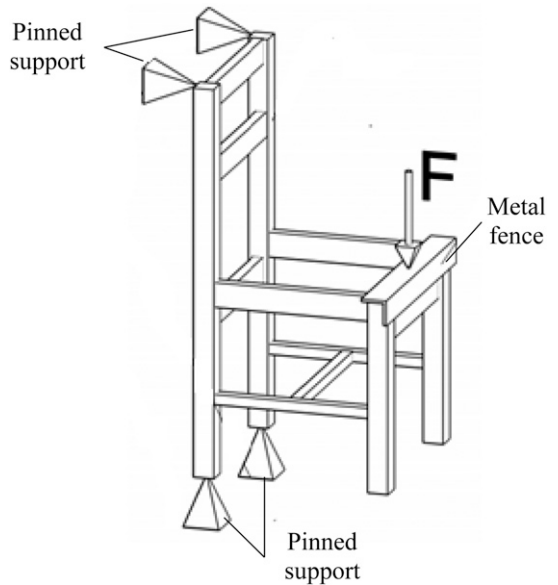

Figure 12. Configuration of static load test for chairs.

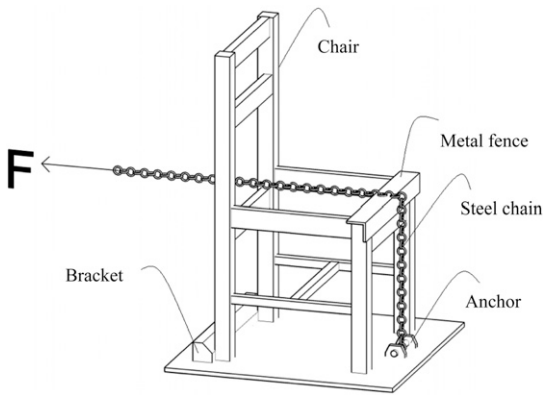

Figure 13. Configuration of the front-to-back cyclic load test for chairs.

Customary (FPS) unit system, so this system must be considered in calculations.

Joint geometry may differ in mortise and tenon joints, so the moment of inertia and dimensional parameter change in calculating its bending stress. In this study, round edge-shaped MT joints are used. Hence, the moment of inertia (I) can be calculated by Hibbeler (2012):

$$I_T = [I_1 + (A_1 \times d_1^2)] + [I_2 + (A_2 \times d_2^2)] + [I_3 + (A_3 \times d_3^2)], \quad (7)$$

$$I_1 = I_3 = \frac{\pi r^4}{8}, \quad (8)$$

$$I_2 = \frac{(2r) \times d^3}{12}, \quad (9)$$

$$A_1 = A_3 = \frac{\pi \times r^2}{2}, \quad (10)$$

$$A_2 = (2r) \times d, \quad (11)$$

$$d_1 = |\bar{y} - y_1|, \quad (12)$$

$$d_2 = |\bar{y} - y_2|, \quad (13)$$

$$d_3 = |\bar{y} - y_3|, \quad (14)$$

where I_T is the moment of inertia of MT; I_1 , I_2 , and I_3 are the moments of inertia for sections 1, 2, and 3, respectively; A_1 , A_2 , and A_3 are the areas of sections 1, 2, and 3, respectively; d_1 , d_2 , and d_3 are the distance between the centerline of tenon and centerlines of sections 1, 2, and 3, respectively; r is the radius of the rounded edge of the tenon. y_1 , y_2 , and y_3 are the distance between the bottom edge of tenon and centerlines of sections 1, 2, and 3, respectively; and \bar{y} is the distance between the centerline of the tenon and the bottom edge of the tenon, as shown in Fig 10.

Construction of Chair Frame

In this study, 20 chair frames made of red oak wood were replicated (ten chairs for cyclic performance test and ten chairs for static performance test). Defect-free furniture members with an MC of 7% were machined. Member sizes are given in Table 1. Because front-to-back cyclic load and statically vertical load on front legs were applied on chairs and most of the failures would occur in these joints, the strength of the joints between side rails to rear legs was investigated. Therefore, MT joints were used to connect side rails to legs, whereas plain dowels (with a diameter of 9.50 mm and length of 25.40 mm) made of red oak wood were used to join front and back rails to legs, as shown in Fig 11. Round mortise and tenon joints (with a diameter of 19.05 mm and length of 22.23 mm) were used to join side stretchers to legs. Midstretchers, connecting side stretchers, were joined with 4.30-mm-diameter and 38.10-mm-long screws.

Performance Test of Chair Frames

Static vertical load test. The load was applied on chair frames as shown in Fig 12. An MTS test

Table 2. Sample statics for bending moment capacity of joints in historical dataset.

Mean	Standard deviation	Variance	CoV	LSL	p-value
350.55 N.m	46.36 N.m	2149.63 N.m	13.23%	211.46 N.m	0.5253

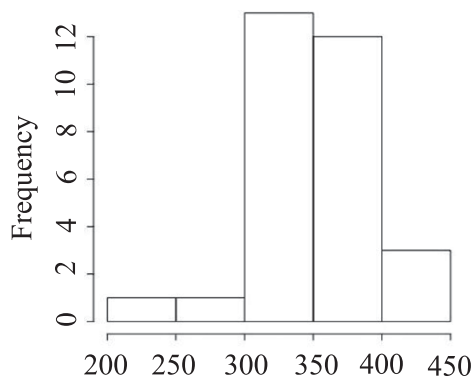

(a)

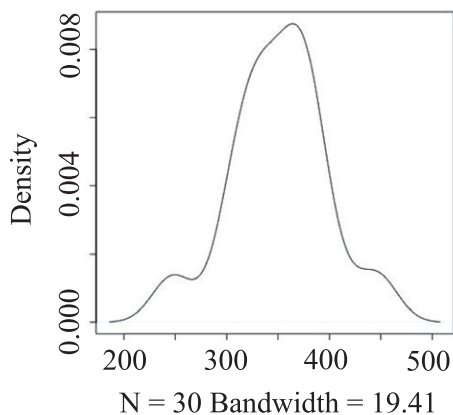

(b)

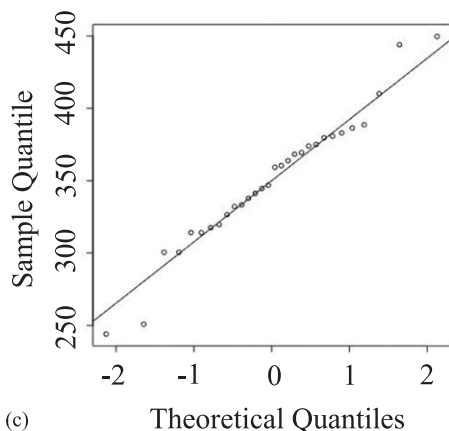

(c)

Figure 14. (a) Histogram, (b) curve-bell, and (c) Q-Q plot of test specimens.

machine was used to apply the load in the middle of the front legs with a rate of 12.7 mm/min. The tests were continued until nonrecoverable failure occurred in one of the MT joints (Likos et al 2012).

Front-to-back cyclic load test. Chair frames were applied stepwise cyclic loading as shown in Fig 13. The tests were conducted according to the American Library Association (ALA) specifications. Loads were applied 20 cycles per minute. The test started with a load level of 111.25 N and stayed at that level until 25,000 cycles were completed. The next load increment was 222.50 N, and 25,000 cycles were completed at each preceding load level. The tests were continued until nonrecoverable failure occurred on any joint or horizontal deflection exceeded 50.80 mm (Eckelman 1995).

RESULTS AND DISCUSSION

Minimum Sample Sizes

Test results for historical data with 30 specimens are given in Table 2. According to the results, the mean of bending moment capacities of T-shaped MT joints made of red oak is 350.55 N.m, with a standard deviation (SD) of 46.36 N.m. and a LSL of 211.46 N.m. Also, the Shapiro–Wilks test shows that the p -value is 0.5235, which is higher than $\alpha = 0.05$, so H_0 is not rejected, and the test indicates significantly that data are normally distributed. Therefore, the modified Faulkenberry–Weeks method could be used to determine minimum sample sizes. Histogram, density, and normal quantile (Q-Q) plots are given in Fig 14(a)-(c), respectively. Q-Q plots show that data are close to normal because the line is close to 45° angle.

Table 3. Sample sizes for each C/P level.

Confidence levels	Proportional levels		
	0.90	0.95	0.99
0.90	9	19	130
0.95	11	20	157
0.99	17	34	215

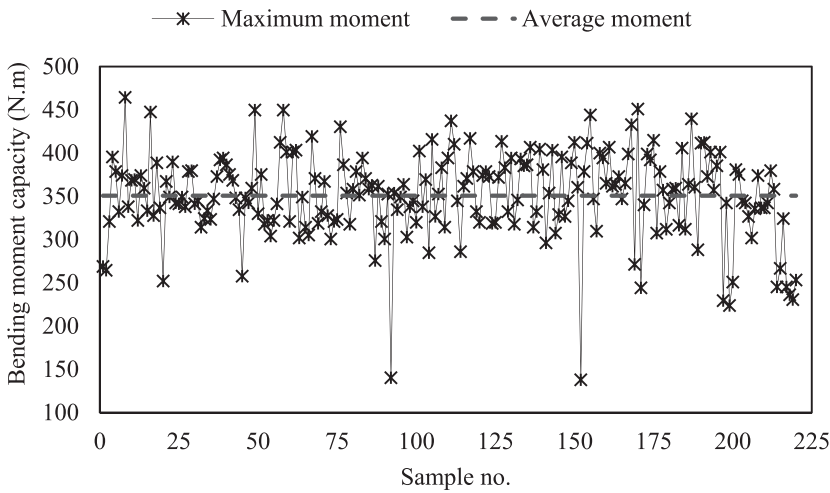

Figure 15. Bending moment capacity of MT joints.

Table 3 shows the minimum sample sizes for selected C/P levels for univariate tolerance analysis. With an increase in the C/P level, the sample size increases because confidence or the proportional level determines the precision and increases uncertainties in the analysis. Therefore, larger sample sizes are needed to address these uncertainties. Besides, changing the proportional level is more effective on sample sizes than changing the confidence levels because the proportion level is related to population, whereas the confidence level is associated with the sample. All in all, at least 215 specimens must be tested to make LTL analysis for 0,99/0,99 C/P level. Five more specimens were constructed to consider the human error rate during sample construction and testing. Therefore, 220 specimens were tested to determine the bending moment capacities of the joints.

Bending Moment Capacity of Joints

The bending moment capacity of T-shaped MT joints made of red oak wood is given in Fig 15 and Table 4. The results show that the average of the bending moment capacity of joints is 350.57 N.m, with a standard deviation of 50.30 N.m. The highest and lowest bending moment capacities of joints were 464.37 N.m and 137.84 N.m. Also,

Fig 16 shows four outliers in the dataset. In general, an outlier in data can be omitted. However, they may be a possible failure of strength for these joint populations, so they were kept in the dataset for tolerance analysis of T-shaped MT joints made of red oak wood.

LTLs of Mortise and Tenon Joints

To make a reliable tolerance analysis, data should be checked whether they are normally distributed or not. Table 4 shows that the *p*-value in the Shapiro–Wilks normality test is lower than 0.05, so that data are not normally distributed. Therefore, normalizing transformation must be sought, which is a logarithmic transformation.

The results show that data are still non-normal after logarithmic transformation. Table 5 indicates that the mean of logarithmic data is 5.85 N.m, with a standard deviation of 0.16 N.m. The *p*-value in the Shapiro–Wilks test is lower than 0.05. Furthermore, Fig 17(a) and (b) indicate the

Table 4. Sample statistics of the T-shaped joint test.

Mean (N.m)	Standard. deviation (N.m)	CoV * (%)	<i>p</i> -value
350.57	50.03	14.27	3.016×10^{-6}

*CoV, coefficient of variation.

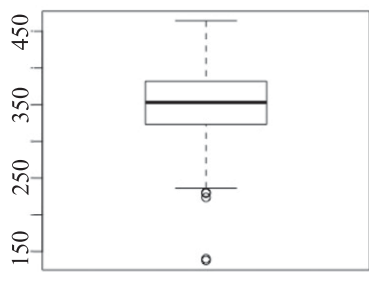
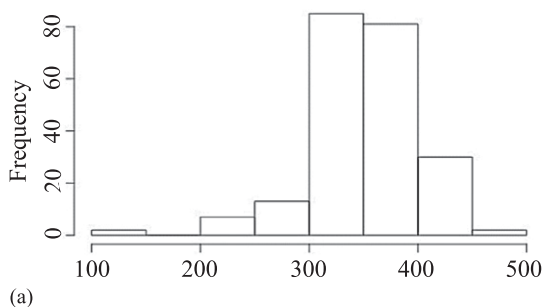

Figure 16. (a) Histogram and (b) box plot of test specimens.

histogram and Q-Q plot, respectively, for the dataset after logarithmic transformation. Thus, another continuous distribution—Weibull distribution—should be sought. According to the Kolmogorov–Smirnov test in Table 6, data do fit into the Weibull distribution since the D -value for this test is 0.0651, which is lower than 0.917. Besides, the p -value in the test is higher than 0.05, and the Q-Q plots in Fig 18(d) show that data are close to normal. The empirical cumulative distribution function in Fig 18(c) indicates that approximately 85% of data are distributed between 300 and 400 N.m.

Under the light of the information mentioned earlier, LTLs were obtained by using `exttol.int` function in tolerance package in R-software. According to test results, LTL values at 95/95, 95/99, 99/95, and 99/99 C/P levels are 251.42 N.m, 247.58 N.m, 203.63 N.m, and 199.05 N.m,

Table 5. Sample statistic of experiment after logarithmic normalizing transformation.

Mean (N.m)	Standard deviation (N.m)	CoV (%)	p -value
5.85	0.16	2.63	3.72×10^{-13}

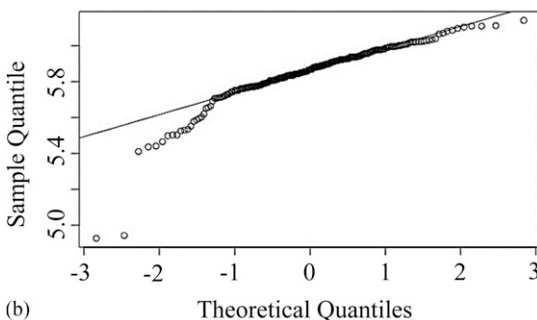
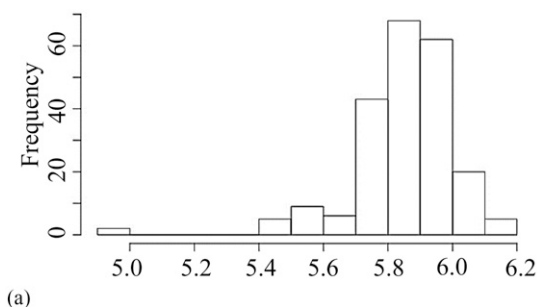

Figure 17. (a) Histogram and (b) Q-Q plot for test specimens after logarithmic normalizing transformation.

respectively (Fig 19). LTL values shown red dash line on dataset in Fig 20 change in proportional level have more effect on the LTL value than a change in confidence level because the proportional level is related to population, whereas the confidence level pertains to the sample size.

Design of the Mortise and Tenon Joints

The rational furniture design dictates that members and joints of a furniture frame can be designed if their bending moment capacity level is known. In tolerance analysis, the bending moment capacity of the joints is used to obtain

Table 6. Kolmogorov–Smirnov test results.

One-sample Kolmogorov–Smirnov test	
Data: MT	
$D = 0.065011$	p -value = 0.3103
Alternative hypothesis: two-sided	

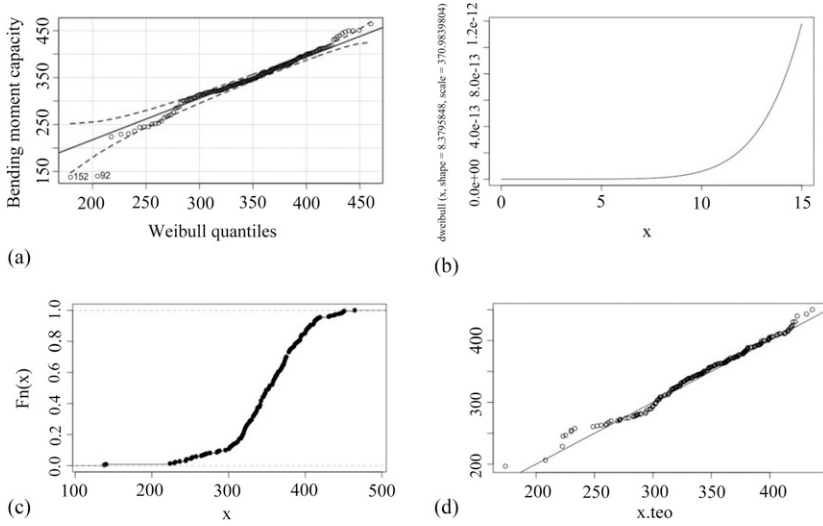

Figure 18. (a) Weibull distribution graph, (b) cumulative Weibull density graph, (c) empirical cumulative distribution function graph, and (d) Q-Q plot for Weibull distribution.

design values for furniture joints. The designed joint was considered a mechanical joint so that its strength relies on bending moment resistance of the tenon itself. However, knowing only the bending moment capacity is not enough to design a reliable joint. Therefore, bending strength, which relies on the bending moment capacity of a joint, and the dimensional parameter of joint cross-section should be used.

As a first step, dimensional parameters of the MT joint shown in Fig 7 were calculated based on Eqs 7-14. The bending strengths of the joints were

determined based on Eq 5 at different C/P levels for mortise and tenon joints. Results are shown in Table 7. Bending strength can be expressed as a design value for MT joints at different C/P levels. A designer can choose any design value according to the required strength of a joint. A design value at the 99/99 C/P level should be chosen to produce the most reliable joints.

In the second step, side frame of the chair defined in Fig 21 was subjected to a 1000 N load level applied on the top of the front post. Structural analysis of the side frame was performed by stiffness method on MATLAB. Bending moment capacity on the side rail to back post of 196 N.m resulted from these analyses. Assuming that a 3/8 router bit (9.525 mm diameter) was used to produce mortise, tenon thickness must be theoretically 9.525 mm. In this case, only diameter d is unknown in the joint geometry, as shown in Fig 10. Under the light of these results, the width and length of the mortise and tenon joints can be determined by using Eqs 6 and 14, respectively.

According to results (Table 8), mortise and tenon joints' geometry was determined to be at least 38.1 mm wide, 22.225 mm long, and 9.525 mm thick, for the scenario that a chair is subjected to a

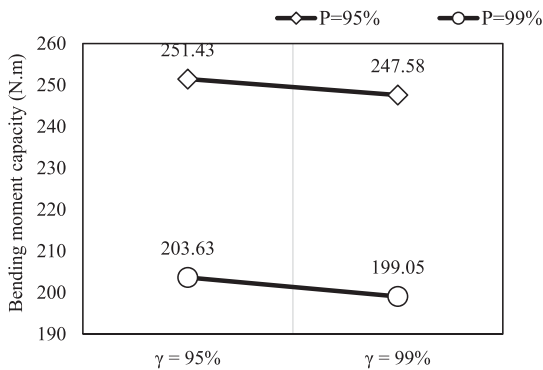

Figure 19. LTL values.

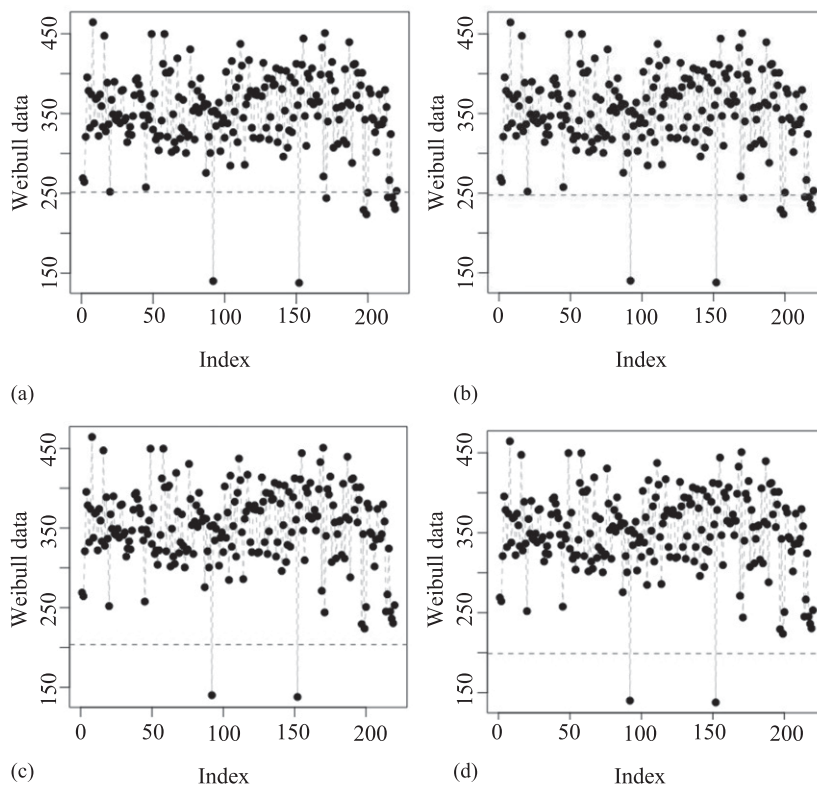

Figure 20. LTL values on data at (a) 95/95, (b) 99/95, (c) 95/99, and (d) 99/99 C/P levels.

vertical load of 2000 N, as shown in Fig 11. As a result, the failure rate should be less than 1% for 99% of chairs.

Performance Tests of Chairs

Results of static and front-to-back cyclic load performance tests show that average load capacities of chairs with MT joints made of red oak wood were 2458.63 N with a standard deviation

of 232.84 N and 1435.19 N with a standard deviation of 123.84 N Fig 22. The load capacity cyclic load performance test was 58.4% of the static load test. These findings are consistent with the previous studies conducted by Kuskun et al (2018).

Table 9 shows individual test results. The chair was designed to endure load-bearing capacity under 2000 N in static load. Test results showed that all tested chairs failed above the load level of

Table 7. Dimensional parameters and bending stresses at different C/P levels.

C/P level	Moment (N.m)	y_1, y_2 (mm)	y_1 (mm)	y_3 (mm)	I_1, I_3 (mm ⁴)	I_2 (mm ⁴)	A_1, A_3 (mm ²)	A_2 (mm ²)	I_T (mm ⁴)	Bending stress (N/mm ²)
95/95	251.43	19.05	35.39	2.74	201.92	18,764.20	35.61	272.65	38,142.60	125.57
99/95	247.58									123.65
95/99	203.63									101.70
99/99	199.05									99.41

Dimensional parameters, shown in Fig 10, were calculated based on Eq 7-14.

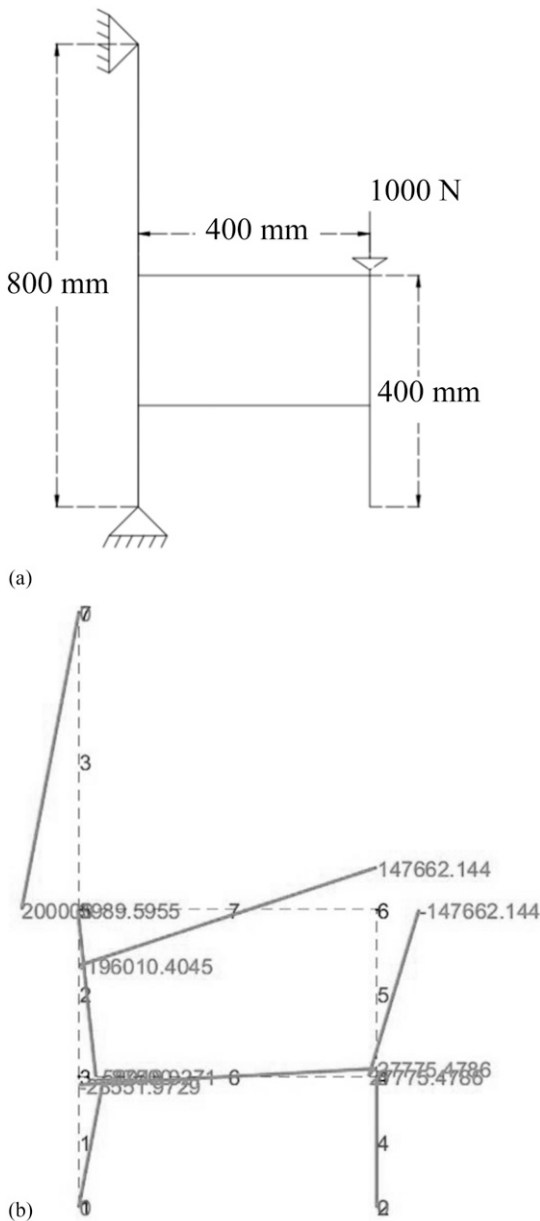

Figure 21. (a) Imposing load on the side frame of a chair, (b) bending moment capacities on side frames (N.mm).

2000 N. This demonstrates that a joint can be safely designed with design values, and its strength can be estimated in the design process. These findings contribute to the engineering design of furniture and provide an opportunity to design and develop structurally sound furniture.

In this study, the test results of the front-to-back cyclic load performance test were compared with ALA specifications (Eckelman 1995), which are 1) 890 N for light-duty service load for household chairs, 2) 1001.25 N for light-duty service load for restaurant chairs, 3) 1335 N for light-duty service load for library chairs, 4) 1557.5 N for medium-duty service load for library chairs, and 5) 2002.5 N for heavy-duty service load for library chairs. According to results shown in Table 10, the strength of all chairs was satisfied by ALA specifications for light-duty household chairs and restaurant chairs, whereas 9, 2, and any chairs met these specifications for light-, medium-, and heavy-duty service load for library chairs, respectively.

CONCLUSION

In this study, a design value for MT joints was estimated by using the LTL method. The design value would help make reliable joints in a furniture frame; namely, a joint strength would be known, and its dimension depending on its geometry would be estimated, which can be endured under imposed load on a construction. Thereby, in the product development process, a designer would know what load level a chair construction (applicable for all frame type construction with MT joints) would be carried.

The use of statistical LTL procedures provides a systematic method to determine the implications of the use of specified fractions of the average capacity of a given joint for design purposes. With this fraction (or called safety of factor for bending strength in static loading), the reliability of a

Table 8. Tenon sizes and parameters in Eq 6.

Thickness (mm)	Width (mm)	Shear parallel to grain (N/mm ²)	Rail/tenon width factor	Adhesive factor	Tenon fit factor	Length factor	Length (mm)
9.52	38.10	14.15	1.33	1.17	0.89	0.83	22.23

Numbers shown in bold are tenon sizes.

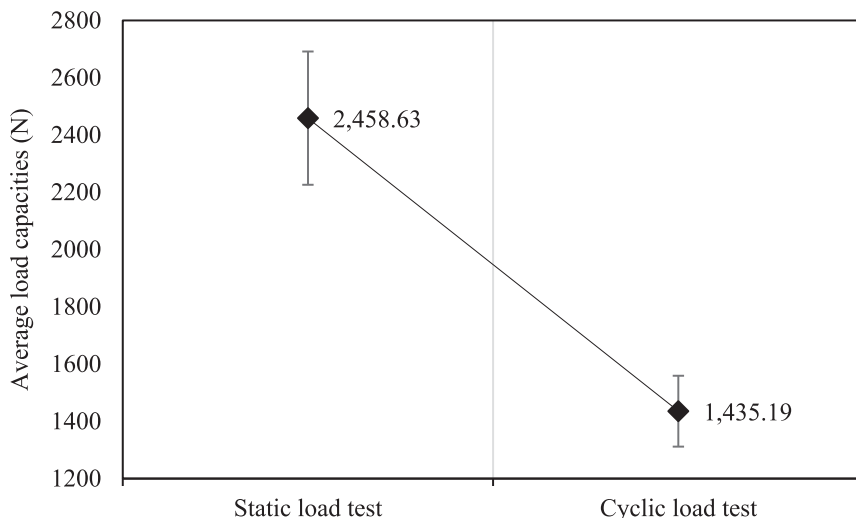

Figure 22. Static and cyclic load capacities of chairs.

furniture frame could be ensured. Consequently, a design value for MT joints made of red oak wood was determined, and conclusions are as follows:

- In tolerance analysis, normality, homogeneity, and randomness assumptions must be considered to obtain reliable findings.
- If data damage normality assumption, tolerance analysis must be performed considering distribution other than a normal distribution.
- The sample size is vital to make reliable tolerance analysis and changes depending on the used C/P level. Therefore, the sample size should be set before setting tolerance limits for data of the sample group.
- In this study, modified Faulkenberry–Weeks methods were used to determine sample sizes for univariate datasets. At least 215 specimens were required to determine LTLs at the 0.99/0.99 C/P level. Larger sample sizes are required with increasing C/P levels.
- Higher C/P levels should be chosen to make reliable products. Hence, the LTL value at the 0.99/0.99 C/P level was chosen as the design value for MT joints made of red oak wood.
- In this study, MT joints were considered as a mechanical joint, so their bending strength was determined and used to design joints.

Table 9. Performance test results of chair frames.

No.	Static failure load (N)	Results (>2000 N)	Cyclic failure load		
			Failure load level (N)	Failure cycle	Ultimate load level (N)
1	2229.45	Pass	1780.00	15,363	1694.23
2	2563.20	Pass	1557.50	1453	1347.93
3	2300.65	Pass	1557.50	18,369	1498.48
4	2767.90	Pass	1780.00	2442	1579.23
5	2371.85	Pass	1335.00	23,493	1321.59
6	2861.35	Pass	1557.50	14,205	1461.42
7	2345.15	Pass	1557.50	127	1336.13
8	2438.60	Pass	1557.50	8852	1413.78
9	2576.55	Pass	1557.50	2038	1353.14
10	2131.55	Pass	1557.50	1235	1345.99
Mean	2458.63	—	—	—	1435.19
Std. dev	232.84	—	—	—	123.84

Table 10. Evaluation of the cyclic performance test results.

Chair no	Cyclic strength (N)	Acceptable light-duty service load for household chairs		Acceptable light-duty service load for restaurant chairs		Acceptable light-duty service load for library chairs		Acceptable medium-duty service load for library chairs		Acceptable heavy-duty service load for library chairs	
		Results	Results	Results	Results	Results	Results	Results	Results		
1	1694.23	890.00 N	Pass	1001.25 N	Pass	1335.00 N	Pass	1557.50 N	Pass	2002.50 N	Fail
2	1347.93		Pass		Pass		Pass		Fail		Fail
3	1498.48		Pass		Pass		Pass		Fail		Fail
4	1579.23		Pass		Pass		Pass		Pass		Fail
5	1321.59		Pass		Pass		Fail		Fail		Fail
6	1461.42		Pass		Pass		Pass		Fail		Fail
7	1336.13		Pass		Pass		Pass		Fail		Fail
8	1413.78		Pass		Pass		Pass		Fail		Fail
9	1353.14		Pass		Pass		Pass		Fail		Fail
10	1345.99		Pass		Pass		Pass		Fail		Fail

- Chairs with MT joints designed to endure 2000 N load levels performed very well under static and cyclic loading. In the static performance test, all chairs failed above 2000 N load level. Besides, in the cyclic performance test, chairs met ALA light-duty service load requirement for household and restaurant chairs, which gives an estimate for furniture life cycle of 7 yr.
- If the design value of a joint is known, the chair can be designed according to its service load. Both anthropometric measurements and standards could provide service load or load level, which should be endured during service life for a chair.

This study is providing an insight to estimate the design values of furniture joints. Accordingly, more reliable constructions can be made and endure specific service loads in use.

ACKNOWLEDGMENTS

This study was supported by the USDA National Institute of Food and Agriculture, Forest Service, the Ministry of National Education of the Republic of Turkey, and Wood Research Laboratory at Purdue University.

REFERENCES

- Domljan D, Grbac I, Bogner A (2004) The role of design in developing of the school furniture. *Wood Ind* 55(2):77-90.
- Eckelman CA (1974) Reasonable design stresses for woods used in furniture. *Purdue Univ Agric Exp Stn Res Bull* 916:1-7.
- Eckelman CA (1995) Library chairs: An overview of the ALA test method with test reports on side chairs. *Libr Technol Rep* 31(2):117-214.
- Eckelman CA (2003) Textbook of product engineering and strength design of furniture. Purdue University, West Lafayette, IN.
- Eckelman CA, Erdil YZ, Haviarova E (2003) School chairs for developing countries: designing for strength and durability, simplicity and ease of construction. *For Prod J* 53(2):63-70.
- Eckelman CA, Erdil YZ, Haviarova E (2006) Effect of shoulders on bending moment capacity of round mortise and tenon joints. *For Prod J* 56(1):82-86.
- Eckelman CA, Haviarova E, Kasal A, Erdil YZ (2017a). Lower tolerance limit approach to equation-based rational design values for T-shaped mortise and tenon joints. *Wood and Fiber Sci* 49(1):113-121.
- Eckelman CA, Haviarova E, Kasal A, Erdil YZ (2017b) Lower tolerance limit approach to equation-based rational design values for L-shaped mortise and tenon joints. *Wood Fiber Sci* 49(2):219-230.
- Eckelman CA, Uysal M, Haviarova E (2016) Statistical lower tolerance limits for rectangular mortise and tenon joints. *BioResources* 11(3):7162-7171.
- Erdil YZ, Haviarova E, Eckelman CA (2004) Product engineering and performance testing in relation. *Wood Fiber Sci* 36(3):411-416.
- Erdil YZ, Kasal A, Eckelman CA (2005) Bending moment capacity of rectangular mortise and tenon furniture joints. *For Prod J* 55(12):209-213.
- Faulkenberry GD, Weeks DL (1968) Sample size determination for tolerance limits. *Technometrics* 10(2): 343-348.
- Fink G, Kohler J (2015) Probabilistic modelling of the tensile related material properties of timber boards and finger joint connections. *Eur J Wood Wood Prod* 73(3):335-346.
- Forest Products Laboratory (2010) Wood handbook: Wood as an engineering material. U.S. Department of Agriculture, Madison, WI. Technical Report FPL-GTR-190. <https://doi.org/General>.

- Hibbeler RC (2012) Structural analysis. MJ Hortan, ed, 8th edition. Pearson Prentice Hall, Upper Saddle River, NJ.
- Hill MD, Eckelman CA (1973) Flexibility and bending strength of mortise and tenon joints. *Furniture Design & Manufacturing*, 1–8. <https://www.agriculture.purdue.edu/fnr/faculty/eckelman/pdf/d197301a.pdf> (24 January 2021).
- Kasal A, Haviarova E, Efe H, Eckelman CA, Erdil YZ (2013) Effect of adhesive type and tenon size on bending moment capacity and rigidity of T-shaped furniture joints constructed of Turkish beech and Scots pine. *Wood Fiber Sci* 45(3):287-293.
- Kasal A, Eckelman CA, Haviarova E, Erdil YZ, Yalcin I (2015) Bending moment capacities of L-shaped mortise and tenon joints under compression and tension loadings. *BioResources* 10(4):7009-7020.
- Khan U, May P, Porwal H, Nawaz K, Coleman JN (2013) Improved adhesive strength and toughness of polyvinyl acetate glue on addition of small quantities of graphene. *Appl Mater Interfaces* 5:1423-1428.
- Kuskun T, Kasal A, Haviarova E, Kilic H, Uysal M, Erdil Y (2018) Relationship between static and cyclic front to back load capacity of wooden chairs, and evaluation of the strength values according to acceptable design values. *Wood Fiber Sci* 50(4):402-410.
- Kwak SG, Kim JH (2017) Central limit theorem: The cornerstone of modern statistics. *Korean journal of Anesthesiology* 70(2):144-156.
- Lane DM (2019) Binomial probability. Pages 203-206 in *Online statistics education: An interactive multimedia course of study*. https://onlinestatbook.com/Online_Statistics_Education.pdf (3 April 2021).
- Lee YL, Makam S, McKelvey S, Lu MW (2015) Durability reliability demonstration test methods. *Procedia Eng* 133: 31-59.
- Likos E, Haviarova E, Eckelman CA, Erdil YZ, Ozcifci A (2012) Effect of tenon geometry, grain orientation, and shoulder on bending moment capacity and moment rotation characteristics of mortise and tenon joints. *Wood Fiber Sci* 44(4):462-469.
- Marra AA (1992) *Technology of wood bending*, 1st edition. Van Nostrand Reinhold, New York, NY.
- Natrella MG (1963) *National bureau of standards handbook 91: Experimental statistics*, U.S. Government Printing Office, Washington, DC.
- Nelson DV (1979) Prediction of fatigue life under irregular loadings. In *Proceeding of the probabilistic mechanics and structural reliability*, Tucson, Arizona. pp. 1-5.
- URL-1, Polhemus NW. Constructing statistical tolerance limits for non-normal data. <http://www.statvision.com/webinars/Nonnormal%20Tolerance%20Limits.pdf> (24 January 2021).
- URL-2, Stibor M, Steel design. <https://structural-analyser.com/domains/SteelDesign/Introduction/> (3 April 2021).
- Uysal M, Haviarova E (2018) Estimating design values for two-pin moment resisting dowel joints with lower tolerance limit approach. *BioResources* 13(3):5241-5253.
- Uysal M, Haviarova E (2019) Lower tolerance limits for screw withdrawal strength in wood. *Wood Fiber Sci* 51(4): 375-386.
- Wencheng L (2011) Principles for determining material allowable and design allowable values of composite aircraft structures. *Procedia Eng* 17:279-285.
- Young DS (2016) Normal tolerance interval procedures in the tolerance package. *R J* 8(2):200-212.
- Young DS, Gordon CM, Zhu S, Olin BD (2016) Sample size determination strategies for normal tolerance intervals using historical data. *Qual Eng* 28(3):337-351.