

WOOD DENSITY AND EXTRACTIVE CONTENT VARIATION AMONG JAPANESE LARCH (*LARIX KAEMPFERI* [LAMB.] CARR.) PROGENIES/PROVENANCES TRIALS IN EASTERN CANADA

Claudia B. Cáceres

Research Associate
E-mail: claudia.caceres@sbf.ulaval.ca

*Roger E. Hernández**†

Professor
E-mail: roger.hernandez@sbf.ulaval.ca

Yves Fortin

Adjunct Professor
E-mail: yves.fortin@sbf.ulaval.ca

Michel Beaudoin

Adjunct Professor
Centre de recherche sur les matériaux renouvelables
Département des sciences du bois et de la forêt
Université Laval, QC, Canada
E-mail: michel.beaudoin@sbf.ulaval.ca

(Received July 2016)

Abstract. Twelve-yr-old Japanese larch (*Larix kaempferi* [Lamb.] Carr.) stems of 20 different progenies and/or provenances were obtained. Two disks of 5 cm thickness were cut at approximately 0.25 and 2.7 m from the ground. Two wedges were cut from each disk to determine basic density at these two heights. The remaining log was used to obtain standard samples for the determination of basic and oven-dry densities closest to the bark. The adjacent material of standard samples was used to produce sawdust for the determination of hot-water extractive content. Basic and oven-dry densities were then corrected by the mass of extractives. Wedge basic density showed a significant variation along the stem. Density was higher at 0.4 m than at 2.75 m in height. However, no significant effect of progeny/provenance was found, nor for basic and oven-dry densities. Once these densities were corrected, the progeny/provenance showed a significant effect, which allowed a progeny grouping by density. Hot-water extractive content was also significantly affected by the progeny/provenance and it varied between 2.9% and 6.9%. Progeny 7280 would have an interesting potential among progeny/provenance for lumber and pulping uses as it showed the lowest water-soluble extractive content, the highest corrected densities, and high growth rate. In general, corrected densities and extractive content would be more appropriate for a preliminary selection of the progenies/provenances according to the final utilization. Further studies of other wood properties would be necessary to confirm these results.

Keywords: Japanese larch, basic density, wood extractives, tree breeding, wood quality.

INTRODUCTION

The genus *Larix* consists of about 10 species distributed throughout the northern hemisphere. Only tamarack is native to eastern Canada (Farrar 1995). Larches are well adapted to northern

climates and grow very quickly when planted in good conditions (Perron 2011). They are versatile species that can be used for numerous purposes, such as lumber products (interior/exterior), pulp and paper, and composite products (Zhang and Koubaa 2008).

In 1970, a larch improvement program was established in Quebec Province to find the most

* Corresponding author

† SWST member

productive and best adapted provenances, hybrids, and clones for this region. Several provenance trials, progenies tests, and/or clonal trials were established to create the database for the establishment of improved seed orchards (Stipanovic 1975). Some species and hybrids of larches (*Larix* sp.) show a very interesting growth rates and effective adaptation to different site conditions, while still producing good-quality wood for lumber and fiber products. The tamarack, European and Japanese larches planted at various sites in Quebec proved to be the most productive conifers when used within rotation periods of 30 yr (Vallée and Stipanovic 1982). Japanese larch produced an average total volume of 0.386 m³ per tree at 22.8 yr against 0.337 m³ at 23.8 yr and 0.255 m³ at 22.6 yr for the European larch and tamarack, respectively (Verville 1981). Another trial test in New Brunswick Province reported that the best provenances of Japanese larch had high productivity and suggested its use as a short-rotation species for fiber production in eastern Canada (Park and Fowler 1983; Fowler et al 1988).

Nowadays, Quebec province is able to increase its forest production by reforestation with improved material through the development of improved varieties. In the boreal forest, despite less favorable growing conditions, the additional volume of lumber obtained by planting improved material is significant, given the extension of the territory and the amount of tree seedlings planted. The development of high-yield plantations, combining intensive forestry and the use of genetically improved material, remains an efficient way to increase forest productivity (Rainville et al 2003).

A species improvement program must take into account the tree morphological and genetic characteristics as well as the wood final utilization. Accordingly, wood properties have become a serious concern among tree breeders. Density is one of the most important properties of wood, as it is relatively easy to measure and it is well correlated to many physical and mechanical properties of wood (Saranpää 2003). However, wood density, which is widely used to evaluate wood quality in tree improvement programs, is highly variable

(Zobel and Van Buijtenen 1989). This variability could be due to genetic, environmental, and physiological factors as well as silvicultural treatments (Panshin and de Zeeuw 1980).

Although growth performance of larches in North America has been well documented, little is known with regard to their wood properties. Verville (1981) mainly studied the variation of physico-mechanical properties of 23-yr-old tamarack, European and Japanese larches planted in Quebec. European larch showed the greatest basic density (427 kg/m³), followed by tamarack (415 kg/m³) and Japanese larch (371 kg/m³). A French study reported that juvenile wood of Japanese and hybrid larches present similar basic density (391 and 396 kg/m³, respectively), but always lower than European larch (460 kg/m³) (Charron et al 2003).

In addition, larches are well known for their high levels of water-soluble extractives. Chemically, the principal water-soluble extractive is arabinogalactan, which is a complex, highly branched polysaccharide (Côté et al 1966; Clarke et al 1979). *Larix* species can contain between 5% and 30% (dry mass) of total arabinogalactans, which are mainly located in the tracheid lumens of earlywood heartwood (Côté et al 1966; Grabner et al 2005). However, Kubo and Kaburagi (1973) reported that about 30% of water extractives of Japanese larch were located inside the cell wall. Some studies have shown that larch arabinogalactan is a promising agent for medical purposes (Riede et al 2013; Babkin 2015; André et al 2015; Dion et al 2016). It is also used as a nutrition supplement (eg ImmunEnhancerTM and FiberAid[®]) (Fitzpatrick et al 2004) and food additive (Ermakova et al 2010). In addition, larch arabinogalactan has been proven potentially valuable as a colloid dispersal agent for the synthesis of nanoscaled materials (Mucalo et al 2002; Gasilova et al 2013).

The objective of this study was to provide an insight on progenies/provenances density variation and the effect of extraneous substances on it. In addition, density and/or water-soluble extractive content were proposed as preliminary selection tools of the best progenies/provenances according to the utilization. This work was part of an extensive

wood quality study of Japanese larch progenies/provenances, which includes dimensional stability and mechanical properties.

MATERIALS AND METHODS

Study Area and Samples

The material for this study was obtained through a larch breeding program established in Quebec. Japanese larch (*Larix kaempferi* [Lamb.] Carr.) trees came from an experimental plantation located in the township of Batiscan (46°31' N and 72°15' W), in the Mauricie region. Seven trees of 20 different progenies and/or provenances were obtained from a selective thinning intervention. Table 1 shows the geographic and genetic origin of the material. The 12-yr-old trees were crosscut at 15 cm from the ground to obtain 140 butt logs of 3 m length. Two disks of 5 cm thick were then cut at approximately 0.25 and 2.7 m of the log big end (0.40 and 2.85 m from the ground) (Fig 1). The mean log diameter at each height and taper of the 20 progenies/provenances is shown in Table 1. Two wedges were cut from each disk to determine basic density at each height. The remaining log was then cut into two slabs. One slab was used to obtain two samples for the determination of basic

and oven-dry densities. The samples were obtained immediately above and below of breast height (1.3 m from the ground). The surrounding material was used to produce the sawdust required for determining extractive content. The sampling distribution pattern is depicted in Fig 1.

Density Assessment

For wedge density evaluation, two 45° opposite wedges were removed at random cardinal directions from each disk (Beaudoin et al 1992). Wedges were kept frozen until measurement of wood density. The green volume of all wedges was obtained with the water displacement method (measured to 0.01 g). Initial MC of the wedges varied from 44% to 172%. Wedges were oven-dried for 24 h at 103°C. The oven-dry mass was then obtained to the nearest 0.01 g after the samples cooled down to room temperature over phosphorus pentoxide. Basic density was calculated as the ratio between oven-dry mass and green volume.

In addition to the wedge density measurements, two samples (25 [T] × 25 [R] × 100 [L] mm) per log (Fig 1) were taken closest to the bark for determining the basic and oven-dry densities. These measurements were made according to

Table 1. Geographic and genetic origin and log characteristics of Japanese larch.

N°	<i>Larix kaempferi</i> [Lamb.] Carr. clone/breed/provenance		Stem diameter (mm)		Taper (mm/m)
	Geographic Origin	Genetic origin	0.40 m	2.85 m	
6689	Honshu, Nagano, Japan	Natural stand	153	125	11
7278	Morayshire, Newton, Scotland	Progeny clone N°3	154	126	12
7279	Morayshire, Newton, Scotland	Progeny clone N°41	178	145	14
7280	Morayshire, Newton, Scotland	Progeny clone N°71	176	132	18
7283	Morayshire, Newton, Scotland	Progeny clone N°V634	161	126	15
7290	Ross-Shire, Scotland	Plantation	173	142	13
7794	Kongenhus, Flensborg, Denmark	Seed orchard	160	129	13
7795	Gavnø, Lindersvold, Denmark	Plantation	157	123	14
8904	Hokkaido, Tokachi, Japan	Breed plantation	156	124	14
8907	Hokkaido, Tokachi, Japan	Breed plantation	161	129	13
8927	Hokkaido, Tokachi, Japan	Breed plantation	162	135	11
8934	Hokkaido, Tokachi, Japan	Breed plantation	158	122	15
8936	Hokkaido, Tokachi, Japan	Breed plantation	148	122	11
8939	Hokkaido, Tokachi, Japan	Breed plantation	163	127	15
8944	Hokkaido, Tokachi, Japan	Breed plantation	162	128	15
8948	Hokkaido, Tokachi, Japan	Breed plantation	161	122	16
8952	Hokkaido, Tokachi, Japan	Plantation	150	123	11
8957	Gavnø, Lindersvold, Denmark	Seed orchard	182	133	20
8962	Honshu, Nagano, Japan	Natural stand	153	119	14
8964	Flensborg, Denmark	Progeny of various clones	137	110	11

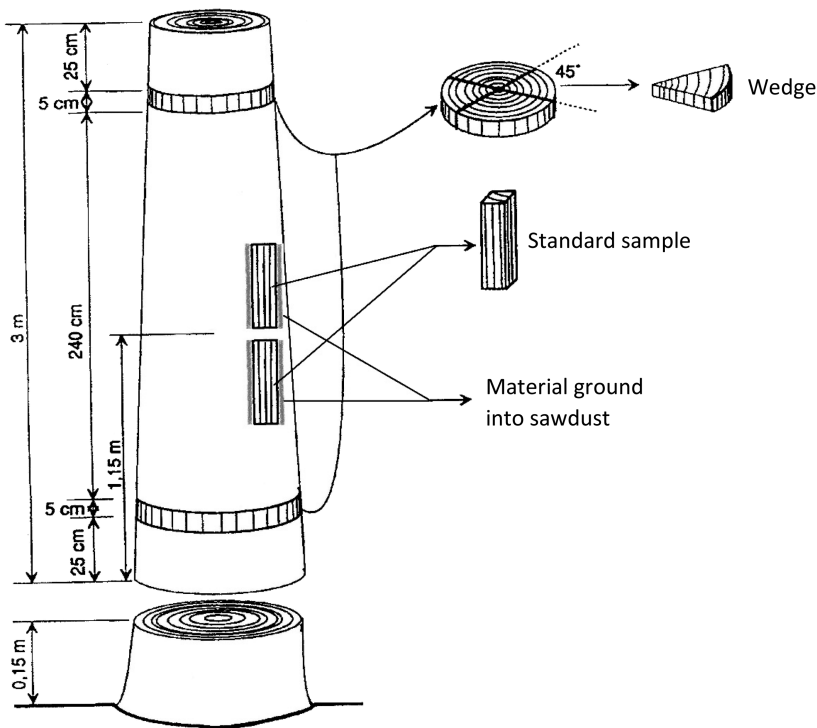

Figure 1. Sampling distribution in the stem.

ASTM D-143-14 specifications for small clear specimens. Green volume of each sample was measured with the water displacement method (measured to 0.01 g). Sample dimensions following the three main directions of wood were taken using a micrometer to 0.01 mm. Afterward, the specimens were slowly air-dried in a conditioning room at 20°C and 80% RH and then at 20°C and 65% RH until a constant mass was reached. The air-dried sample mass and their dimensions were measured. Thereafter, the specimens were oven-dried by gradually increasing the temperature until reaching 103°C. Mass and oven-dry dimensions were then measured. The specimens were subsequently paraffined to measure the dry volume by immersion in distilled water.

Extractive Determination

The tangential adjacent parts of the standard samples were ground to produce sawdust (Fig 1). The fragmentation procedure was intended to optimize the proportion of material retained

between 20 and 70 mesh screens (0.210–0.841 mm), while minimizing the production of very fine particles (Campbell and Bryant 1937). Hot-water solubility was assessed according to American Society for Testing and Materials (ASTM) D1110-84 (2001). Two air-dried samples of 2 g per board were mixed with 100 mL of distilled water. Samples were extracted in Erlenmeyer flasks provided with reflux condensers. After 3 h of gentle boiling, material was transferred to a tared filter paper, washed with 1000 mL of hot distilled water, and oven-dried. Hot-water solubility is reported on an oven-dry mass basis, as the ratio of extracted to unextracted wood (as a percentage). Finally, basic and oven-dry densities determined for standard samples were corrected for the extractive content according to Hernández (2007) using the following formula:

$$D_{oc} = \frac{M_{oc}}{V_o} = \frac{M_o}{V_o} (1 - e) = D_o (1 - e) \quad (1)$$

where M_{oc} denotes the oven-dry mass without extraneous substances, V_o is the oven-dry volume,

M_o is the overall oven-dry mass, and e is hot-water soluble extractives as a fraction. The same principle was applied for corrected basic density. The applied formula shows that correction of density was performed on the oven-dry mass only, but this does not take into account the effect that extraneous substances can have on the volume changes in wood.

Statistical Analysis

Data were analyzed using the statistical analysis system (SAS[®]) software, version 9.4. Raw data were first evaluated with the Box-Cox method showing the more fitted transformation if required. A mixed model of analysis of variance (ANOVA) was used to evaluate the variation of density and hot-water extractive content ($\alpha \leq 0.05$). For wedge samples, data structure followed a split-plot design with progeny/provenance in the main plot and sampling height in the subplot. The progeny/provenance was the studied source of variation for standard samples and hot-water extractives. Multiple comparison tests were done using the least-squares means statement (lsmeans) at 5% probability level if necessary.

Finally, the normality was verified with Shapiro-Wilk's test, the homogeneity of variance was verified with the graphical analysis of residuals.

RESULTS AND DISCUSSION

Density

The mean basic density for twenty progenies/provenances of Japanese larch varied between 381 and 417 kg/m³, for the wedge samples. Basic density of standard samples varied from 369 to 413 kg/m³, whereas oven-dry density varied from 409 to 463 kg/m³. In all cases, the lower and higher values corresponded to progeny/provenance 6689 and 7283, respectively (Table 2). Basic density of standard samples was a little lower than that of wedges, which could be attributed to the differences in sampling location within the stem (radial and axial variation). Wedge density represents the mean density of the stem at one specific height. Table 2 shows the mean wedge density at the two stem heights evaluated (0.40 and 2.85 m). Standard sample density is related to a radial position. In this case, the samples were taken closest to the bark at breast height (Fig 1).

Table 2. Basic and oven-dry densities from 20 progenies/provenances of Japanese larch.

Progeny/provenance	Basic density		Oven-dry density—standard samples (kg/m ³)
	Wedges (kg/m ³)	Standard samples (kg/m ³)	
6689	381	369	409
7278	409	408	460
7279	405	397	445
7280	396	406	460
7283	417	413	463
7290	385	376	419
7794	393	398	444
7795	411	395	443
8904	399	395	443
8907	397	393	435
8927	396	387	432
8934	395	399	444
8936	417	392	438
8939	406	404	453
8944	404	394	440
8948	398	387	432
8952	384	378	435
8957	403	398	448
8962	395	390	434
8964	409	400	445

The ANOVA showed no significant effects of progenies or provenances on wood density (Table 3). Nevertheless, Japanese larch trees of 17 yr old from 20 seed sources planted in New Brunswick showed a highly significant basic density variation among provenances (385–417 kg/m³) (Loo et al 1982). The density variation range is similar between these two studies. However, Loo et al (1982) had a higher number of sampled trees per provenance (30 trees) compared with our study (7 trees), which allowed to effectively dissociate intertree variation from provenance variation.

On the other hand, variation in basic density of wedges along the butt log was significant (Table 3). Density decreased with increasing height in the log. Thus, density at 0.40 m from the ground (408 kg/m³) was higher than the one at 2.85 m (392 kg/m³). Similar results were reported by Isebrands and Hunt (1975) for Japanese larch as well as by Okkonen et al (1972), Keith and Chauret (1988), and Chui and MacKinnon-Peters (1995) for other larches. This variation is mainly related to the proportional amounts of different cell types and by the dimension of the cells, especially thickness of the cell wall (Heger 1974).

Corrected Density

Japanese larch progeny/provenance had not significant effect on basic and oven dry densities measured on standard samples. However, progeny/provenance showed a significant effect once these densities were corrected for the presence of extractives (Table 3). These results are in agreement with observations in *Pinus echinata*, which indicated that extractives masked

the actual specific gravity differences between provenances (Posey et al 1970).

Density is determined by several cell characteristics. However, chemical deposits within and between the cells can drastically affect density (Zobel and Van Buijtenen 1989). Taras and Saucier (1967) found that the extractive content overestimated the amount of lignocellulosic material by 6–7.5% in southern pines. Most of Japanese larch water-soluble extractives are deposited in the lumen of both earlywood and latewood tracheids, but some of them are inside the cell wall too (Kubo and Kaburagi 1973). Hence, corrected densities (Tables 5 and 6) were lower than uncorrected densities (Table 2). Basic and oven-dry densities corrected by the mass of extractives ranged from 348 and 386 kg/m³ to 394 and 447 kg/m³ for provenance/progenies 6689 and 7280, respectively (Tables 5 and 6). These values are lower by 21% and 23% to 12% and 13%, respectively, compared with their corresponding uncorrected densities (Table 1). Basic density is an important property of the pulpwood. Although volume has been the parameter measured in trading, the pulping yield relates more closely to the amount of dry wood substance than to the volume of wood (Spångberg and Nylinder 1997). Therefore, a potential use of the corrected basic density appears interesting for the pulp and paper industry as it allows a better estimation of the amount of lignocellulosic material in a given volume of wood.

The multiple comparisons tests for corrected densities (Tables 5 and 6) showed that progenies/provenances density classes have a wide range, with a significant overlap among classes due to

Table 3. *F*-values obtained from the ANOVAs for basic densities, oven-dry densities, and hot-water extractive content.

Source of variation	Basic density		Oven-dry density—standard samples	Hot-water extractive content	Standard samples	
	Wedges	Standard samples			Corrected basic density	Corrected oven-dry density
	<i>F</i> -values					
P/P	1.4 ns	1.42 ns	1.65 ns	2.42*	2.34*	2.57*
Height	47.29*	ni	ni	ni	ni	ni
P/P × height	1.22 ns	ni	ni	ni	ni	ni

P/P, progeny/provenance; ni not included in the ANOVA; ns, not significant.

* Significant at the 0.01 probability level.

the small sample size. As explained earlier, a higher number of trees should have increased the discrimination power among progenies/provenances. However, these results can help in the progeny/provenance selection process according to the utilization. Corrected density would be more appropriate for a selection of the best progeny/provenance when the density of lignocellulosic material is the main issue. The progeny 7280 had the lowest extractive content (Table 4), the highest corrected densities (Tables 5 and 6), also showed one of the fastest growth rates (Table 1). This suggests a good potential of this progeny/provenance for pulping purposes.

Extractives

Hot-water extractive content of Japanese larch varied between 2.9 to 6.9% for progenies/provenances 7280 and 8907, respectively (Table 4). The ANOVA showed a significant effect of provenance on extractive content (Table 3). Therefore, progenies/provenances of Japanese larch could be selected by extractive content at early stages. The trees for this study

Table 4. Multiple comparisons tests of hot-water extractive content from 20 progenies/provenances of Japanese larch.

Progeny/provenance	Hot-water extractive content (%)					
7280	2.9	A				
7279	3.8	A	B			
7278	4.0	A	B	C		
8939	4.0	A	B	C		
8944	4.2		B	C	D	
8936	4.7		B	C	D	
8927	4.7		B	C	D	
8962	4.8		B	C	D	
8948	4.9		B	C	D	
8952	5.0		B	C	D	E
8964	5.1		B	C	D	E
7794	5.2		B	C	D	E
7290	5.4			C	D	E
8904	5.5			C	D	E
7795	5.5			C	D	E
8957	5.5			C	D	E
6689	5.5			C	D	E
8934	5.7			C	D	E
7283	6.2				D	E
8907	6.9					E

Means followed by the same letter are not significantly different at 5% probability level.

Table 5. Multiple comparisons tests of corrected basic density from 20 progenies/provenances of Japanese larch.

Progeny/provenance	Corrected basic density—standard samples (kg/m ³)						
7280	394	A					
7278	392	A	B				
8939	388	A	B	C			
7283	388	A	B	C			
7279	382	A	B	C	D		
8964	380	A	B	C	D	E	
8944	378	A	B	C	D	E	
7794	377	A	B	C	D	E	
8934	377	A	B	C	D	E	
8957	376	A	B	C	D	E	
8936	373	A	B	C	D	E	F
7795	373	A	B	C	D	E	F
8904	373	A	B	C	D	E	F
8962	371	A	B	C	D	E	F
8927	368		B	C	D	E	F
8948	368		B	C	D	E	F
8907	366			C	D	E	F
8952	359				D	E	F
7290	356					E	F
6689	348						F

Means followed by the same letter are not significantly different at 5% probability level.

came from a 12 yr old plantation. According to Zhu et al (2000), the limit between juvenile and mature wood in Japanese larch varies between age 15 and 21 depending on the plantation site. Therefore, it would be reasonable to state that all the material used in this experience was composed of juvenile wood. Extractive removal in young trees is usually not done because the difference between extracted and unextracted density is not very high. Generally, older trees with different amount of heartwood will have a more important extractive content (Zobel and Van Buijtenen 1989). However, Chui and MacKinnon-Peters (1995) found that European larch of 17 yr old had the highest mean extractive content compared with older Japanese and hybrid larches. Contrary to common belief, extractive content in young trees may not be low. Isebrands and Hunt (1975) found extractive content values between 2% and 6% for individual growth rings on 10 yr old Japanese larch trees. This is consistent with our results, although the extraction methods were different. Extractive content was obtained after an extraction sequence of benzene - ethanol - hot water. Accordingly, extractive

Table 6. Multiple comparisons tests of corrected oven-dry density from 20 progenies/provenances of Japanese larch.

Progeny/provenance	Corrected oven-dry density—standard samples (kg/m ³)				
7280	447	A			
7278	441	A	B		
7283	435	A	B	C	
8939	435	A	B	C	
7279	428	A	B	C	
8957	423	A	B	C	D
8964	423	A	B	C	D
8944	422	A	B	C	D
7794	420	A	B	C	D
8934	419	A	B	C	D
7795	419	A	B	C	D
8904	419	A	B	C	D
8936	417	A	B	C	D
8962	413		B	C	D E
8927	411		B	C	D E
8948	411			C	D E
8907	405			C	D E
8952	398				D E
7290	396				D E
6689	386				E

Means followed by the same letter are not significantly different at 5% probability level.

content could be taken into consideration as another variable for tree early selection on improvement programs.

Some studies have shown that the extraction method, tree age, and wood type (sapwood/heartwood) also had an effect on the extractive content. Keith and Chauret (1988) reported average values of 2.3% and 8.5% in European larch of 25 yr old, for extractions with ethanol-benzene and hot water, respectively. Srinivasan et al (1999) found that hot-water extractives in tamarack of 75 yr old from New Brunswick varied between 1.9% and 4.8% in sapwood and between 7.6% and 24.7% in heartwood. Moreover, hot-water extractives in larches were very variable among trees (from 5.7% to 20.5% of dry weight), but not significant variation was found among species (39-yr-old European, Japanese, and hybrid larches) (Gierlinger et al 2004). Therefore, if there is an industrial interest on extraneous substances production, all of these parameters must be taken into consideration for an early assessment of the raw material.

The presence of extractives in the heartwood has been largely related to its decay resistance.

However, the natural durability of eastern larch heartwood to brown rot fungi was found to be moderate to low. It was suggested that high amounts of arabinogalactans could enhance fungal growth by being a nutrient source (Srinivasan et al 1999). Gierlinger et al (2004) reported that resistance to decay was instead strongly correlated to phenolic contents (acetone extractives). Moreover, water-soluble extractives could also affect the processing of larch wood. Arabinogalactans may stick in saw blades during saw milling, potentially causing sawing inaccuracies and interruptions (Sairanen 1982). Consequently, progenies/provenances with the higher amounts of water-soluble extractives would be less interesting from a wood machining point of view.

In the case of pulping, one of the criteria for selecting wood is having raw material with a low level of extractives. Overall, extractive content in this work can be considered low due to the young age of sampled trees (12 yr) since they had not yet formed heartwood. Hence, this age seems suitable for plantations destined for pulp and paper purposes. However, extractive content increases as soon as wood matures. Japanese larch intertree extractive content variation was important, which probably corresponded to the beginning of heartwood formation in some trees. Nevertheless, progenies/provenances 7280, 7279, 7278, and 8939 may be preferred for pulping as they exhibited the lowest extractive content (Table 4). At the opposite, progenies/provenances 8952, 8964, 7794, 7290, 8904, 7795, 8957, 6689, 8934, 7283, and 8907 could be preferred as source of water-soluble extractives (arabinogalactans). Arabinogalactans have shown great potential for medical uses (Babkin 2015; André et al 2015; Dion et al 2016) and for the synthesis of nanoscaled materials (Mucalo et al 2002; Gasilova et al 2013). They have also been used in the food industry (Fitzpatrick et al 2004; Ermakova et al 2010).

Overall, density classification and extractive content could be good initial selection factors of Japanese larch progenies/provenances. The complementary studies on Japanese larch progenies/provenances wood quality, including shrinkage

and mechanical properties, will give additional criteria for a more effective selection in terms of the requirements of the final wood product.

CONCLUSIONS

Japanese larch basic density obtained from the wedges showed a significant variation with the stem height. Density was higher at 0.4 m than at 2.75 m in height. The progeny/provenance effect was not significant, neither for wedge nor standard samples densities. However, once standard samples densities were corrected for the mass of hot-water extractives, the progeny/provenance effect became significant. Therefore, corrected densities would be more adequate for a density differentiation of lignocellulosic material among progenies/provenances. Hot-water extractive content was also significantly affected by the progeny/provenance, although the material for this study could consider all juvenile wood. Early selection of Japanese larch progenies/provenances in improvement programs could consider corrected densities and extractive content to meet specific industry end uses appropriately. Ongoing studies on the same material, including mechanical properties and dimensional stability, will provide further information for the selection of the best progenies/provenances.

ACKNOWLEDGMENTS

Funding for this project was provided by the Ministry of Forest, Wildlife, and Parks of Quebec. The authors thank Ante Stipanovic and Martin Perron for their valuable assistance. The authors also thank Hristo Iliev for his contribution during the laboratory experiences.

REFERENCES

- André S, Classen B, Gabius H-J (2015) Studies on unprocessed and acid-treated arabinogalactan from larch as an inhibitor of glycan binding of a plant toxin and biomedically relevant human lectins. *Planta Med* 81(12-13): 1146-1153.
- American Society for Testing and Materials (ASTM) (2001) Standard test methods for water solubility of wood. D1110-84. American Society for Testing and Materials, West Conshohocken, PA.
- American Society for Testing and Materials (ASTM) (2014) Standard test methods for small clear specimens of timber. D143-14. American Society for Testing and Materials, West Conshohocken, PA.
- Babkin VA (2015) Theoretical and practical development of new drugs for medicine based on larch biomass extracts. *Russ J Bioorganic Chem* 41(7):679-685.
- Beaudoin M, Hernández RE, Koubaa A, Poliquin J (1992) Interclonal, intraclonal and within-tree variation in wood density of poplar hybrid clones. *Wood Fiber Sci* 24(2): 147-153.
- Campbell WG, Bryant SA (1937) The sampling of wood for analysis, with particular reference to the Australian eucalypts. *Biochem J* 31:748-754.
- Charron S, Jourez B, Marchal M, Hebert J (2003) Comparison study of physical and mechanical characteristics of European (*Larix decidua* Mill.), Japanese (*Larix kaempferi* (Lambert) Carr.) and hybrid (*Larix x eurolepis* Henry) larch woods. *Biotechnol Agron Soc Environ* 7(1):5-16 [In French].
- Chui YH, MacKinnon-Peters G (1995) Wood properties of exotic larch grown in eastern Canada and north-eastern United States. *For Chron* 71(5):639-646.
- Clarke A, Anderson R, Stone B (1979) Review: Form and function of arabinogalactans and arabinogalactan-proteins. *Phys Chem Chem Phys* 18(4):521-540.
- Côté WA, Day AC, Simson BW, Timell TE (1966) Studies on larch arabinogalactan I. Distribution of arabinogalactan in larch wood. *Holzforschung* 20(6): 178-192.
- Dion C, Chappuis E, Ripoll C (2016) Does larch arabinogalactan enhance immune function? A review of mechanistic and clinical trials. *Nutr Metab* 13:28.
- Ermakova MF, Chistyakova AK, Shchukina LV, Pshenichnikova TA, Medvedeva EN, Neverova NA, Belovezhets LA, Babkin VA (2010) Effect of arabinogalactan isolated from Siberian larch on the baking value of soft wheat flour and bread quality. *Russ J Bioorganic Chem* 36(7):951-956.
- Farrar JL (1995) Trees of the northern United States and Canada. Fitzhenry and Whiteside Ltd, Ottawa, Canada. 502 pp.
- Fitzpatrick A, Roberts A, Witherly S (2004) Larch arabinogalactan: A novel and multifunctional natural product. *Agro Food Ind Hi-Tech* 15(1):30-32.
- Fowler DP, Simpson JD, Park YS, Schneider MH (1988) Yield and wood properties of 25-year-old Japanese larch of different provenance in eastern Canada. *For Chron* 64(6): 475-479.
- Gasilova ER, Matveeva GN, Aleksandrova GP, Sukhov BG, Trofimov BA (2013) Colloidal aggregates of Pd nanoparticles supported by Larch Arabinogalactan. *J Phys Chem B* 117(7):2134-2141.
- Gierlinger N, Jacques D, Schwanninger M, Wimmer R, Pâques LE (2004) Heartwood extractives and lignin content of different larch species (*Larix* sp.) and relationships to brown-rot decay-resistance. *Trees (Berl)* 18(2):230-236.

- Grabner M, Wimmer R, Gierlinger N, Evans R, Downes G (2005) Heartwood extractives in larch and effects on X-ray densitometry. *Can J For Res* 35(12):2781-2786.
- Heger L (1974) Longitudinal variation of specific-gravity in stems of black spruce balsam fir and lodgepole pine. *Can J For Res* 4(3):321-326.
- Hernández RE (2007) Influence of accessory substances, wood density and interlocked grain on the compressive properties of hardwoods. *Wood Sci Technol* 41(3):249-265.
- Isebrands JG, Hunt CM (1975) Growth and wood properties of rapid-grown Japanese larch. *Wood Fiber Sci* 7(2): 119-128.
- Keith CT, Chauret G (1988) Basic wood properties of European larch from fast-growth plantations in eastern Canada. *Can J For Res* 18(10):1325-1331.
- Kubo T, Kaburagi J (1973) Basic studies on wood properties in Japanese Larch (*Larix leptolepis*) I. The distribution of water-soluble extractives and wood properties in Japanese Larch. *Bulletin of the Experiment Forests*. Tokyo University of Agriculture and Technology 10:108-115 [In Japanese].
- Loo J, Fowler DP, Schneider MH (1982) Geographic variation in specific gravity among Japanese larch from different provenances. *Wood Fiber Sci* 14(4):281-286.
- Mucalo MR, Bullen CR, Manley-Harris M, McIntire TM (2002) Arabinogalactan from the Western larch tree: A new, purified and highly water-soluble polysaccharide-based protecting agent for maintaining precious metal nanoparticles in colloidal suspension. *J Mater Sci* 37(3): 493-504.
- Okkonen EA, Wahlgren HE, Maeglin RR (1972) Relationships of specific gravity to tree height in commercially important species. *Forest Prod J* 22(7):37-42.
- Panshin AJ, de Zeeuw C (1980) *Textbook of wood technology: structure, identification, properties and uses of the commercial woods of the United States and Canada*. McGraw-Hill, New York, NY. 722 pp.
- Park YS, Fowler DP (1983) A provenance test of Japanese larch in eastern Canada, including comparative data on European larch and tamarack. *Silvae Genet* 32(3-4): 96-101.
- Perron M (2011) *Le mélèze hybride du québec: performant et race*. Note de recherche forestière n°3. Ministère des Forêts, de la Faune et des Parcs, Quebec. 2 pp [In French].
- Posey CE, Bridgway FE, Walker N (1970) Effect of seed origin on tracheid length, specific gravity, and volume of shortleaf pine in Oklahoma. *For Sci* 16(1):66-70.
- Rainville A, Desponts M, Beaudoin R, Périnet P, Mottet M-J, Perron M (2003) *L'amélioration des arbres au Québec: un outil de performance industrielle et environnementale*. Note de recherche forestière n° 127. Ministère des Forêts, de la Faune et des Parcs, Quebec, Canada. 8 pp [In French].
- Riede L, Grube B, Gruenwald J (2013) Larch arabinogalactan effects on reducing incidence of upper respiratory infections. *Curr Med Res Opin* 29(3):251-258.
- Sairanen P (1982) Properties and usages of larch in the mechanical forest industry in Soviet Union. *Metsäntutkimuslaitoksen tiedonantoja*, 72 [In Finnish].
- Saranpää P (2003) Wood density and growth. Pages 87-117 in Barnett JR and Jeronimidis G, eds. *Wood quality and its biological basis*. Blackwell, Oxford, UK.
- Spångberg K, Nylinder M (1997) Development of a method for sorting *Picea abies* pulpwood with respect to basic density. *Scand J For Res* 12(1):65-69.
- Srinivasan U, Ung T, Taylor A, Cooper PA (1999) Natural durability and waterborne preservative treatability of tamarack. *Forest Prod J* 49(1):82-87.
- Stipanovic A (1975) *L'amélioration du genre mélèze (Larix sp.) au service de la recherche du Ministère des terres et forêts*. Note de recherche forestière n° 20. Ministère des Forêts, de la Faune et des Parcs, Quebec, Canada. 37 pp [In French].
- Taras MA, Saucier JR (1967) Influence of extractives on specific gravity of southern pine. *Forest Prod J* 17(9): 97-99.
- Vallée G, Stipanovic A (1982) Growth and performance of larch plantation. Pages 47-63 in Faculty of Forestry, University of Toronto: Ministry of Natural Resources, eds *Proc Larch Symposium, potential for the future*, November 9, 1982, Toronto, Ontario.
- Verville A (1981) *Étude physico-mécanique de quelques espèces du genre Larix en plantation*. MS thesis, Université Laval, Quebec, Canada. 115 pp [In French].
- Zhang SY, Koubaa A (2008) Exotic larches. Pages 9.1-9.17 in *Softwoods of Eastern Canada: Their silvics, characteristics, manufacturing, and end-uses*. Special Publication SP-526E. FPInnovations, Quebec, Canada.
- Zhu JJ, Nakano T, Hirakawa Y (2000) Effects of radial growth rate on selected indices for juvenile and mature wood of the Japanese larch. *J Wood Sci* 46(6):417-422.
- Zobel B, Van Buijtenen JP (1989) *Wood variation: Its causes and control*. Springer-Verlag, Berlin, Germany. 363 pp.