

ULTRASONIC DETECTION OF KNOTS AND ANNUAL RING ORIENTATION IN *PINUS RADIATA* LUMBER

José T. Karsulovic

Associate Professor
Department of Wood Engineering

Luis A. León

Assistant Professor
Department of Wood Engineering
Universidad de Chile
Facultad de Ciencias Forestales
Casilla 9206, Santiago, Chile

Luis Gaete

Professor
Department of Physics
Universidad de Santiago de Chile
Casilla 200, Santiago, Chile

(Received April 1999)

ABSTRACT

An ultrasonic defect detection system for radiata pine lumber based on 0.5 Mhz sound transmission through wood was tested. The feasibility of detecting knots, grain deviation, and growth ring angle with this system was investigated as well. The knot material, area of knot influence, and growth ring angle were significantly correlated to wave velocity. The ultrasonic scanning showed good agreement with visual prediction.

Keywords: Ultrasonic waves, knot detection, growth ring angle.

INTRODUCTION

The improvement of wood productivity requires automation of the different production stages. The information obtained by automatic classification can also provide a basis to determine an optimal strategy for cutting boards.

Boards exhibit various types of defects, both on the surface and internally, which vary widely in size and shape. Grading of boards is usually done by human operators, and the maximum potential yield is reduced by human judgment errors. While knot material can be readily identified in *Pinus radiata*, knot size as visually determined by the boundary between a knot and clear wood is very subjective.

Detection of knots in *Pinus radiata* lumber is especially important because they are

among the most numerous and severe defects. Reduction in strength and stiffness associated with knots is often qualitatively attributed to grain deviation in the wood immediately surrounding knots. No quantitative data pertaining to grain deviation associated with knots are currently available; however, it is often recognized that the area of local grain deviation is the most significant factor in reduction of mechanical properties. Furthermore, it produces difficulty in wood machining and gluing. This problem becomes critical in finger-jointing and in edge gluing, when cross-cutting is very near the knot material.

The flow-grain analogy (Phillips et al. 1981) was employed to develop empirical relationships between knot diameter and pertinent variables: grain deviation angle near the knot and area of influence of the knot. Cha-

zelas et al. (1988), using an acoustic method, showed the changes in the elastic behavior of wood induced by the presence of tight or loose knots.

Szymani and Mc Donald (1981) defined and classified lumber defects, specified the requirements of an automated defect detection system, and described various methods that have potential for defect detection in lumber (optical, ultrasonic, microwave, X-ray, and neutron). From this study it is apparent that a comprehensive defect detection system may require a combination of methods, depending on its application. After comparing the selected methods for defect detection in lumber, these authors concluded that the most promising internal defect detection method is ultrasonic sensing. A major disadvantage is that the ultrasonic transducer must be mechanically coupled to the material being tested. However, at present it is possible to use rolling transducers for planed wood.

Tests for defect detection in lumber using acoustic methods were conducted using immersion and through-transmission (McDonald 1978; Szymani and McDonald 1981).

No commercial device has been designed for in-line quality control of logs or lumber, but improving the accuracy and inspection velocity may assist in the implementation of this technique. However, the use of ultrasound grading for structural timber has been shown by Sandoz (1989, 1993), proving that a good correlation exists between the ultrasonic wave velocity and modulus of rupture or the modulus of elasticity in static bending. Ultrasonic stress grading was developed as an improved alternative to visual grading.

Several reports have shown the relationship between sound velocity and morphological and mechanical properties of wood (Bucur 1997). However, little information is available on the combined effect of growth ring angle and curvature of rings on the ultrasonic velocity in wood. The continuum theory employed in ultrasonic characterization using an orthotropic model ignores this curvature. However, both factors are related with knot formation.

Despite its sensitivity, versatility, and simplicity, the ultrasound technique suffers some difficulties due to material variability, coupling conditions of the transducer, and other set-up related factors. Although some of these variables can be controlled in the laboratory, commercial application is still a challenge. It is hoped that in the near future this practical and cost-effective technique will be considered a valuable alternative or complementary method to improve the grading system.

The aim of this study was to develop a scanning ultrasonic system for detecting knots and annual ring orientation in radiata pine boards.

THEORETICAL CONSIDERATIONS

Basically, the interaction of ultrasonic wave propagation with the structure of the material gives parameters for the characterization of material properties. The presence of defects in testing specimens brings about changes in these parameters which indicate their occurrence. Linking ultrasonic velocity measurements with the physical laws that govern the propagation of acoustic waves in orthotropic solids provides a tool for the interpretation of the results of nondestructive trials in lumber.

The development of the transmission technique for precise measurement of the grain angle in wood was based on the ultrasonic waves in wood governed by the Christoffel equation for orthotropic solids (Bucur 1995). The Cartesian orthotropic model is used to study wood structure using plane wave propagation and to characterize its elastic behavior. Wood has three axes of symmetry: the longitudinal axis (L), which is parallel to the fiber grain; the radial axis (R), which is orthogonal to the growth rings (perpendicular to the grain in the radial direction); and the tangential axis (T), which is perpendicular to the grain but tangential to the growth rings.

The Christoffel equation gives the relationship between elastic constants and ultrasonic velocities. For an orthotropic solid, nine constants must be determined. If this equation is solved for the wave propagation directions

along the axes of symmetry of an orthotropic solid, we get three solutions, each of which shows that along every axis it is possible to have three types of waves that can propagate: one of them has its displacement vector parallel to the propagation direction (longitudinal wave), and the other two have orthogonal transverse displacement vectors (shear waves).

For wood characterization, the ultrasonic technique consists of measuring velocities first along the symmetry directions and then in directions at various angles to the axis of symmetry. The ultrasonic behavior of wood with respect to its elastic behavior has been the subject of numerous theoretical considerations covered in a number of standard references (Bucur and Archer 1984).

The velocity of sound in wood is influenced by the species, moisture content, temperature, and anatomical direction since the propagation velocity in a solid depends on the elastic properties and density.

EXPERIMENTAL METHODS

Ultrasonic velocity in wood

Small samples were tested before studying the effect of growth ring angle on acoustic waves. For measuring the ultrasonic velocities, 20-mm cubes were used; this dimension was selected to give an adequate signal in wood. This sample size also gives a better approximation to rectangular orthotropy, as the curvature of the annual rings may be neglected.

The sample material consisted of seven groups of growth ring angles (0° , 15° , 30° , 45° , 60° , 75° , and 90°) with 60 specimens per group. The cubes were cut from 6 planed boards, obtaining these angles with respect to the rotation around the longitudinal axis (parallel to grain). All specimens were equilibrated at a nominal EMC of 12%, their densities being determined under such conditions. For this study, growth ring angle was measured between the direction of wave propagation and the radial plane (Fig. 1).

The ultrasonic technique used is based on the transmitting pulse method. The propaga-

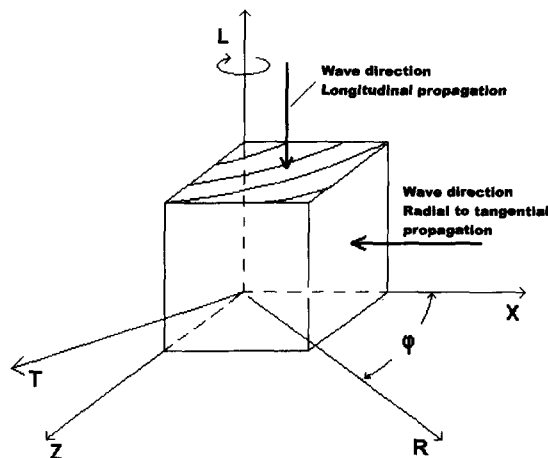

FIG. 1. Ultrasonic measurements for the different ring angles in cubic specimens of 20 mm.

tion velocity was determined by measuring the specimen length and the travel time of the acoustic wave. The ultrasonic pulse was generated by the Panametrics ultrasonic analyzer that combines a pulse/receiver. The ceramic piezoelectric transmitting and receiving transducers were identical at 0.5 Mhz for longitudinal waves. The diameter of the transducers was 25 mm. For the transmission of waves into the wood specimen, the coupling agent at each interface was SWC-Panametrics resine. The travel time was measured with a Metrix analogue/digital OX8620 oscilloscope. Measurement accuracy was $0.01 \mu\text{s}$.

Test for defect detection

Experiments were carried out using $40 \times 125 \times 800$ -mm samples selected and cut from planed boards of radiata pine of $40 \times 125 \times 4000$ mm. On their wide faces, the samples contained sound knots of six different sizes with diameters ranging from approximately 25 to 55 mm (measured cross to edge and considering only knot material). The samples were selected so that each of them showed variable growth ring angles. The average moisture content of the lumber was found to be approximately 10% at the time of the experiment.

The wide face of the blocks was marked

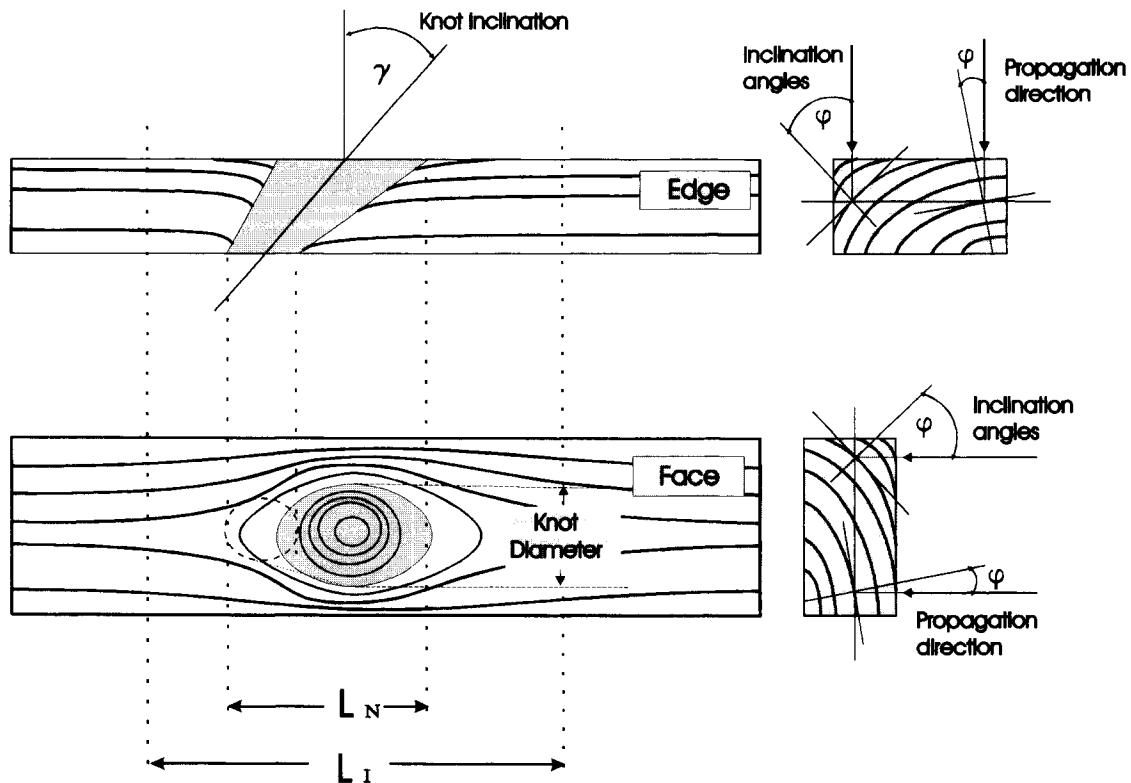

FIG. 2. Sketch showing measurements of knot diameter and inclination length of knotted zone (L_N), influence zone (L_I) and growth ring angle.

with a grid for positioning the transducers. Nine equally spaced locations were marked in the width direction defining longitudinal grid lines 15 mm apart. Cross-section lines 15 mm apart intersected longitudinal grid lines, making 180 grid points on each wide face.

After measuring the transit time, the blocks were cross-cut according to each transversal grid line. On each location in the width marked with longitudinal grid lines, the

growth ring angle was measured with respect to the tangent to the growth ring and orthogonally to the wave propagation direction. This procedure allowed us to study the effect of the knot, associated grain angle, and annual ring slope on the acoustic wave.

For the analysis of the ultrasonic scanning of knots, the parameters knotted zone (L_N) and zone of knot influence (L_I) were defined as shown in Fig. 2. These parameters were contrasted with the actual characteristics of the knots of each sample, knot diameter and inclination being established as shown in this figure.

TABLE 1. Ultrasonic velocities of waves in orthotropic directions, in cubic samples of 20 mm.

	Density (kg/m^3)	Velocities of waves ($n = 57$)(m/s)		
		V_L	V_R	V_T
Mean value	444	5952	2079	1690
Maximum	527	6712	2482	1872
Minimum	362	4435	1895	1473
Absolute error	44	487	152	105
Relative error (%)	9.9	8.2	7.3	6.2

RESULTS AND DISCUSSION

Anisotropy of ultrasonic velocities as influenced by changes in wood densities

Table 1 summarizes the results of the ultrasonic velocities in the orthotropic directions of

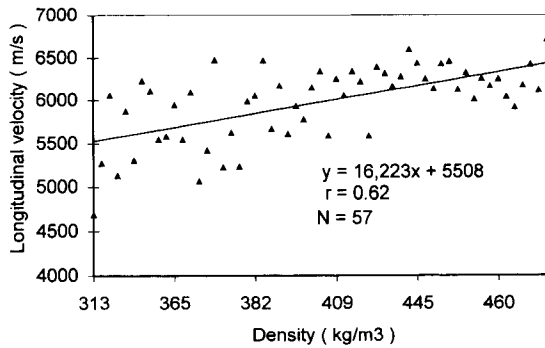

FIG. 3. Relationships between ultrasonic velocities in the longitudinal directions and densities.

small (20-mm) cubic radiata pine samples and their densities at the time of testing. As expected, ultrasonic velocities were the fastest in the longitudinal directions (V_L), followed by those in the radial directions (V_R), while the slowest were those in the tangential directions (V_T).

The relationship between the ultrasonic velocity in tangential, radial, and longitudinal directions and densities (Figs. 3 and 4) indicates that ultrasonic velocities in the longitudinal directions tended to increase with increased densities ($r = 0.64$ for linear regression), while in the radial and tangential directions, they tended to decrease with increased densities ($r = -0.59$ and $r = -0.34$, respectively, for linear regression).

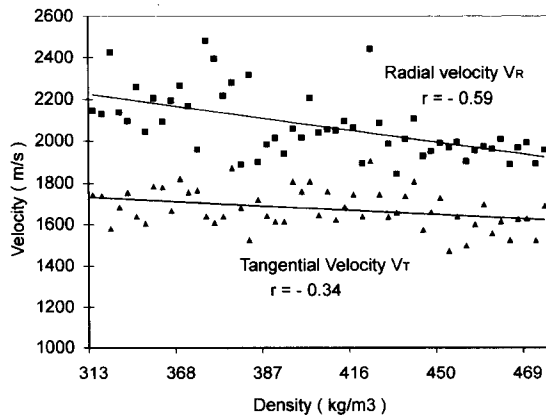

FIG. 4. Relationships between ultrasonic velocities in the radial and tangential direction vs. densities.

TABLE 2. Anisotropy of wood in terms of ratio of velocities in longitudinal (V_L), radial (V_R) and tangential (V_T) directions.

	Ratio of velocities (n = 57)		
	V_L/V_R	V_L/V_T	V_R/V_T
Mean value	2.89	3.56	1.23
Absolute error	0.37	0.39	0.097
Relative error (%)	12.7	10.9	7.9

The anisotropy of wood in terms of velocity ratios was estimated for the velocity of waves in the orthotropic directions. It is evident from Table 2 that the LT plane exhibits a greater ratio of anisotropy; however, for the objective of this study, the V_R/V_T ratio is of greater interest in showing that the mean variation range of 23% enables differences in velocity to be detected between both directions, with a relative error of 8%.

Figure 5 shows the effects of wood density on the ratio of radial to tangential velocities, which tended to decrease with increased density ($r = -0.52$ for linear regression).

Test for growth ring angle

Table 3 gives the variation of the ultrasonic velocities on small samples at different angles of rings defined by the rotation of the RT plane with respect to the longitudinal axis L. It is observed that with a relative error of 7%, it is possible to establish velocity differences

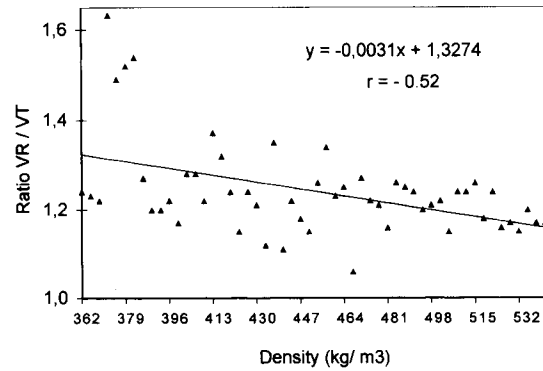

FIG. 5. Relationships between ratio radial to tangential velocities and densities.

TABLE 3. Variation of the ultrasonic velocities for different ring angles as defined by rotation plane RT with respect to the longitudinal axis (L) ($\varphi = 0^\circ$ velocity in radial direction).

Growth ring angle φ (Degrees)	Velocity (m/s) (n = 57)		
	Mean value	Absolute error	Relative error %
0	2079	152	7.3
15	1961	97	4.8
30	1838	115	6.2
45	1625	106	6.5
60	1609	110	6.8
75	1667	94	5.3
90	1690	105	6.2

for variations of ring angles between 0 and 90 degrees.

Investigation of the effect of growth ring angle on wave propagation shows a relationship between wave velocity and rotation angle φ (Fig. 6). A polynomial regression of mean values of propagation velocity in 57 samples for each ring angle gave a close correlation ($r = 0.99$). The radial direction of wave propagation corresponds to the fastest velocity. In contrast, a wave-focusing effect would be expected for 45° because of the lowest velocity in this plane. However, the lowest velocity was at a 60° angle, which agrees with results obtained by Biernachi and Beall (1993).

On the basis of the above data, one may assume that an acoustic wave preferably follows the direction of greater stiffness.

The results obtained of the density effect on wave propagation from the radial to tangential direction show that density accounts for only 35% of the velocity variations in the radial direction and 12% in the tangential direction. Therefore, it is possible to infer that the main cause of velocity variation between these directions is due to the stiffness differences of the medium.

Knot and growth ring angle detection

Among the different mappings obtained, Fig. 7 is shown here to illustrate the velocity of the ultrasonic waves with orthogonal propagation to all the points of the grid on the sur-

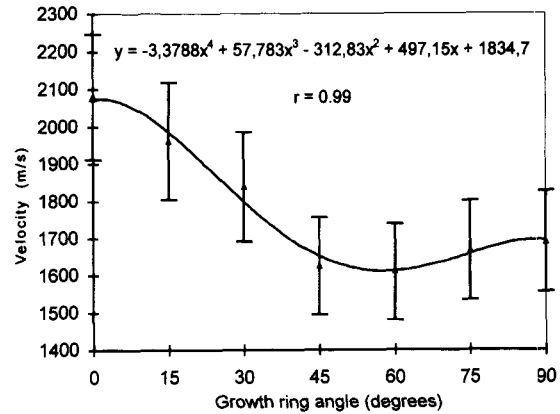

FIG. 6. Relationship of velocity with growth ring angle. Mean values of 57 samples per each ring angle.

face of one specimen with one knot of 55 mm of diameter and with ring angle varying between 5 and 35 degrees. The knot presence is distinctly seen in contrast with normal wood. In all the patterns obtained, it was noticeable that the maximum wave velocity almost corresponded to the knotted volume centroid. An area of local grain deviation (area of knot influence) that resulted proportional to knot diameter is clearly recognized.

This mapping also reveals the changes in growth ring angle shown by the different gray color intensities of the longitudinal strips, which are observable in all the samples showing this particularity. These color strips represent the velocity gradients when the propagation direction changes from radial to tangential. These changes are greater than the velocity changes induced by the density variation that can be expected in a same sample. The mapping was obtained by means of a software that enables one to plot velocity variations of 100 m/s every 10 degrees of ring variation angle.

Complementing the information on knot detection shown in Fig. 7, Fig. 8 shows, in quantitative terms, the velocity variations in three lengthwise paths, two of which pass over the knot material and the third, outside the knot and knot influence. The highest velocity of the knotted zone can be seen here in contrast to

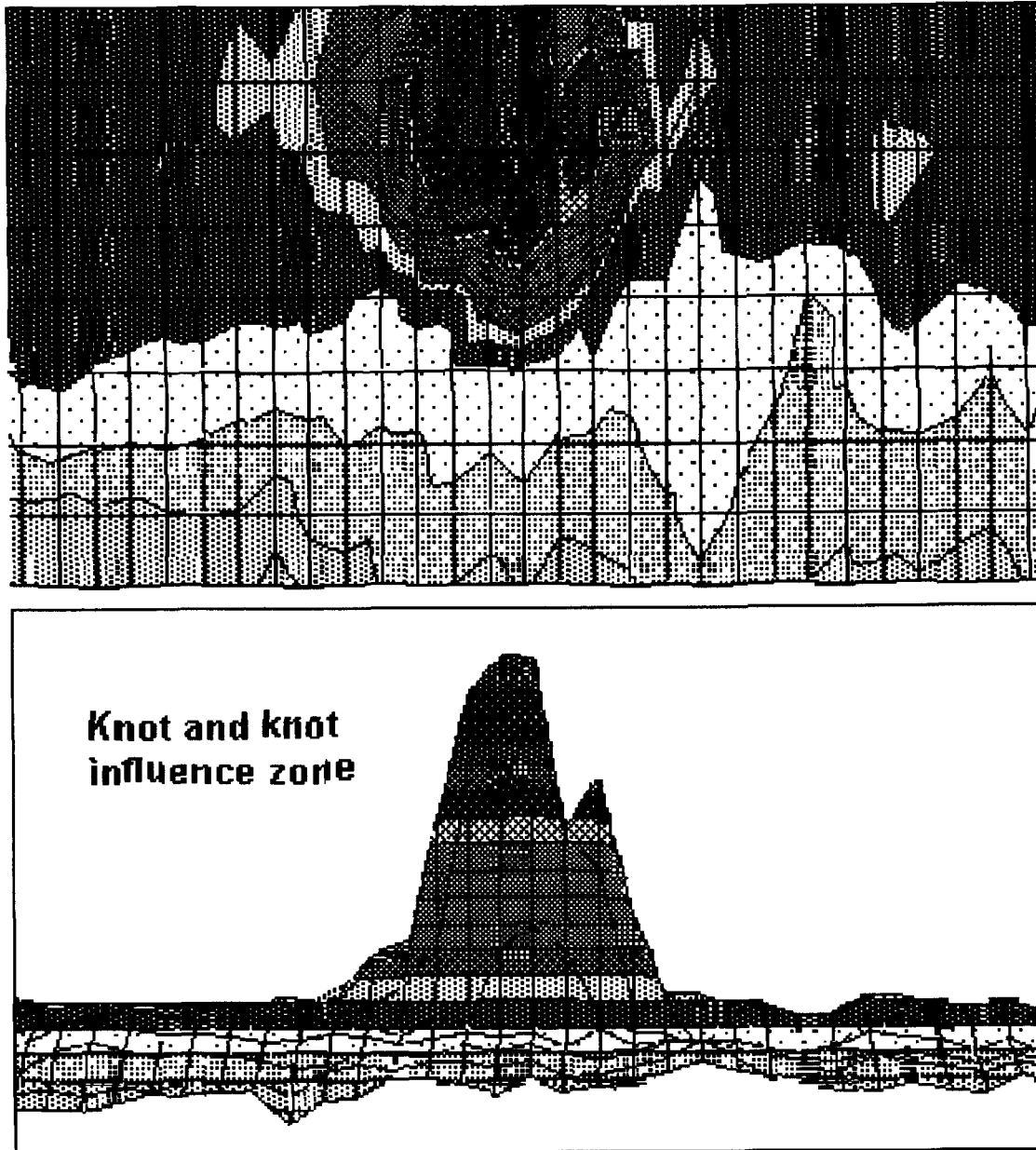

FIG. 7. Ultrasonic scanning of knot showing its influence zone and growth ring variation. Above: Bidimensional view Below: Tridimensional view.

normal wood. Moreover, the limits between knot material and the zone of knot influence are evident.

On the other hand, Table 4 gives values between the length of the knotted zone and that

of the zone of knot influence, the average ratio being approximately 2. These results were obtained from the analysis of the ultrasonic scanings of all the studied knotted samples. The contrasting with the actual dimensions of the

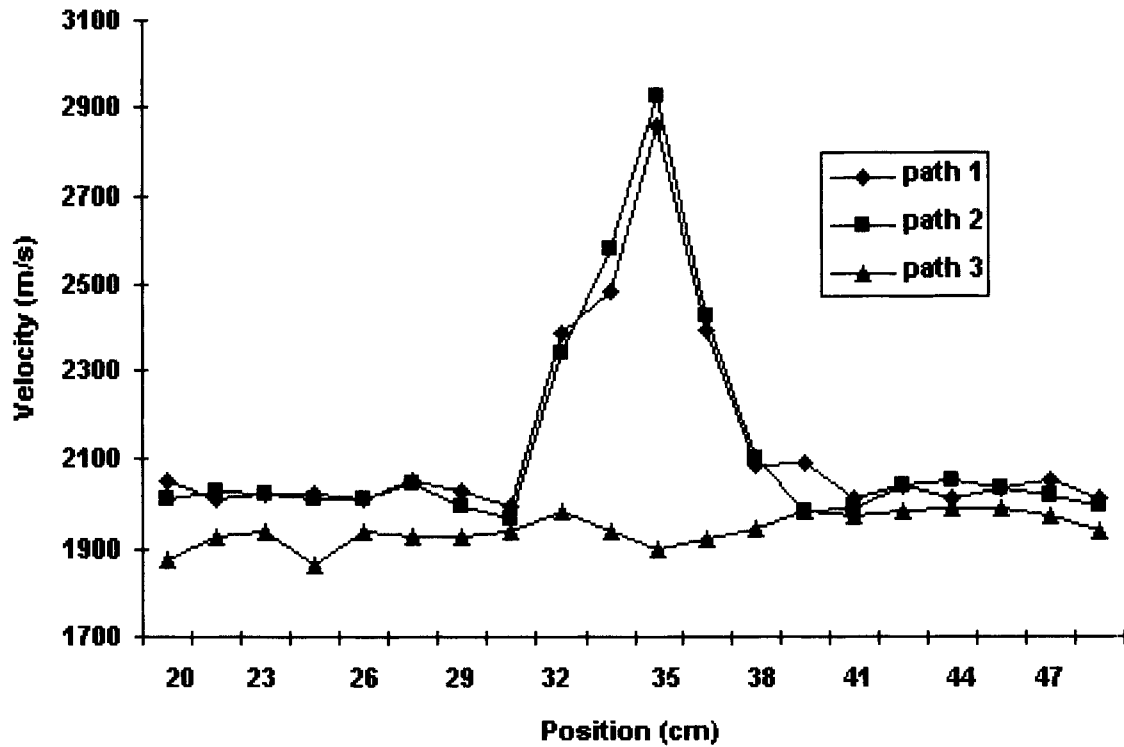

FIG. 8. Variation of longitudinal velocity for three paths along the sample. Paths 1 and 2 on the knot. Path 3 in normal wood outside the knot and its influence zone.

knots showed a very well adjusted correspondence.

Lastly, it should be noted that ultrasonic velocity of wave propagation was significantly correlated to growth ring angle for all specimens ($r = 0.91$ average).

CONCLUSIONS

In the characterization of radiata pine wood, it was found that for clear wood the effect of growth ring angle on ultrasonic wave propa-

gation is the major factor of the variability in sound velocity transmission perpendicular to the grain. The changes were generated mainly by the stiffness variations in that direction, the wood density having little influence.

Scanning of the knotted specimens and with ring angle showed that the ultrasonic method is a valuable technique for detecting knots, zones of knot influence, and growth ring angle for radiata pine. In board inspection, scanning of only one surface is sufficient to obtain the

TABLE 4. Ratio between length of zone of knot influence (L_I) and length of knotted zone (L_N)

Specimen	Knot diameter (cm)	Knot inclination γ (degrees)	L_N (cm)	L_I (cm)	Ratio L_I/L_N
1	5.5	37.3	9	17	1.9
2	3.0	47.0	8	18	2.3
3	7.0	50.0	12	24	2.0
4	4.0	28.7	6	14	2.3
5	3.0	26.3	7	12	1.7
6	2.5	21.8	5	10	2.0

two-dimensional pattern representing the internal faults and other discontinuities.

More research is needed in this area to develop techniques suitable to assess overall wood quality, as in grading, or to locate particular defects using ultrasonic waves.

ACKNOWLEDGMENTS

The authors wish to thank the Fondo de Investigación Científica y Tecnológica FONDECYT (Scientific and Technological Research Fund, Projects N° 1960419 and 1990680) for the financial support of this project that made this publication possible.

REFERENCES

- BIERNACKI, J. M., AND F. C. BEALL. 1993. Development of an acoustic ultrasonic scanning system for nondestructive evaluation of wood and wood laminates. *Wood Fiber Sci.* 25(3):289-297.
- BUCUR, V. 1987. Wood characterization through ultrasonic waves. Pages 323-342 in A. Alippi and W. G. Mayer, eds. *Ultrasonic methods in the evaluation of inhomogeneous materials*. Martinus Nijhoff Publ., Dordrecht, Boston, Lancaster.
- . 1995. *Acoustic of wood*. CRC Press, Inc., Boca Raton, FL 284 pp.
- , AND R. R. ARCHER. 1984. Elastic constants for wood by an ultrasonic method. *Wood Sci. Technol.* 18: 255-265.
- CHAZELAS, J. L., A. VERGNE, AND V. BUCUR. 1988. Analyse de la variation des propriétés physiques et mécaniques locales du bois autour des noeuds. Pages 376-386 in *Actes du colloque comportement mécanique du bois*. June 8-9, Bordeaux, France.
- MCDONALD, K. A. 1978. Lumber defect detection by ultrasonics. Res. Pap. No. FPL 311. USDA, Forest Prod. Lab., Madison, WI.
- PHILLIPS, G. E., J. BODIG, AND J. R. GOODMAN. 1981. Flow grain analogy. *Wood Sci.* 14(2):55-64.
- SANDOZ, J. L. 1989. Grading of construction timber by ultrasound. *Wood Sci. Technol.* 23: 95-108.
- . 1993. Moisture content and temperature effect on ultrasound timber grading. *Wood Sci. Technol.* 27:373-380.
- SZYMANI, R., AND K. A. MCDONALD. 1981. Defect detection in lumber: State of the art. *Forest Prod. J.* 31(11): 34-44.